

# HP StorageWorks SN6000 Fibre Channel Switch Installation and Reference Guide

Part Number: 5697-0260  
Published February 2010  
Edition: 1



## Legal and notice information

© Copyright 2010 Hewlett-Packard Development Company, L.P.

© Copyright 2010. This software includes technology under a license from QLogic Corporation. All rights reserved.

The information contained herein is subject to change without notice. The only warranties for HP products and services are set forth in the express warranty statements accompanying such products and services. Nothing herein should be construed as constituting an additional warranty. HP shall not be liable for technical or editorial errors or omissions contained herein.

Java® is a registered trademark of Sun Microsystems, Inc.

Microsoft®, Windows®, and Internet Explorer® are registered trademarks of Microsoft Corporation.

Netscape Navigator® and Mozilla® are registered trademarks of Netscape Communications Corporation.

## HP StorageWorks SN6000 Fibre Channel Switch Installation and Reference Guide



# Contents

About this guide . . . . .	7
Intended audience . . . . .	7
Related documentation . . . . .	7
Document conventions and symbols . . . . .	8
Rack stability . . . . .	9
HP technical support . . . . .	9
Customer self repair . . . . .	9
Product warranties . . . . .	9
Subscription service . . . . .	9
HP websites . . . . .	10
Documentation feedback . . . . .	10
<b>1 General description . . . . .</b>	<b>11</b>
Switch LEDs and controls . . . . .	12
Input power LED (green) . . . . .	12
Heartbeat LED (green) . . . . .	12
System fault LED (amber) . . . . .	12
Maintenance button . . . . .	13
Resetting a switch . . . . .	13
Placing the switch in maintenance mode . . . . .	13
Fibre Channel ports . . . . .	14
Port LEDs . . . . .	15
Port Logged-in LED (green) . . . . .	15
Port Activity LED (green) . . . . .	15
Transceivers . . . . .	15
Port types . . . . .	15
Ethernet port . . . . .	17
Serial port . . . . .	17
Power supplies and fans . . . . .	18
Switch management . . . . .	19
QuickTools web applet . . . . .	19
Simple SAN Connection Manager . . . . .	19
Command line interface . . . . .	19
Simple Network Management Protocol . . . . .	20
Storage Management Initiative–Specification (SMI-S) . . . . .	20
File transfer protocols . . . . .	20
<b>2 Planning . . . . .</b>	<b>21</b>
Devices . . . . .	21
Device access . . . . .	21
Performance . . . . .	22
Distance . . . . .	22
Bandwidth . . . . .	22
Latency . . . . .	23
Feature licenses . . . . .	23
Multiple switch fabrics . . . . .	23
Optimizing device performance . . . . .	23
Domain ID, principal priority, and domain ID lock . . . . .	24
Stacking . . . . .	24
Common topologies . . . . .	26
Transparent routing . . . . .	26
Switch services . . . . .	28
Security . . . . .	30
User account security . . . . .	30

IP security . . . . .	30
Port binding . . . . .	30
Connection security . . . . .	30
Device security . . . . .	31
Fabric management . . . . .	32
<b>3 Installation . . . . .</b>	<b>33</b>
Site requirements . . . . .	33
Management Station and Workstation requirements . . . . .	33
Switch power requirements . . . . .	34
Environmental conditions . . . . .	34
Installing a switch . . . . .	34
Mount the switch . . . . .	35
Before you begin . . . . .	35
Collect the required items . . . . .	36
Verify the kit contents . . . . .	36
Rack the switch. . . . .	37
Install the transceivers. . . . .	39
Configure the workstation . . . . .	39
Configuring the workstation IP address for Ethernet connections . . . . .	39
Configuring the workstation serial port . . . . .	39
Apply power to the switch . . . . .	40
Connect the management station or workstation to the switch . . . . .	41
Configure the switch . . . . .	41
Simple SAN Connection Manager switch configuration . . . . .	41
QuickTools switch configuration . . . . .	42
CLI switch configuration. . . . .	42
Cable devices to the switch. . . . .	42
Installing firmware . . . . .	43
Using QuickTools to install firmware . . . . .	43
Using the CLI to install firmware. . . . .	44
One-step firmware installation . . . . .	44
Custom firmware installation . . . . .	45
Adding a switch to an existing fabric . . . . .	45
Installing feature license keys . . . . .	46
Configuring Call Home to HP Services (optional) . . . . .	46
Role of the Remote Support Software Manager . . . . .	46
Role of OSEM and versions required . . . . .	46
Installation instructions and documentation for SIM, RSP, OSEM, and ISEE . . . . .	47
RSP requirements for the CMS . . . . .	47
Infrastructure requirements for implementing Call Home to HP Services . . . . .	48
Configuring Call Home to HP services. . . . .	48
<b>4 Diagnostics and troubleshooting . . . . .</b>	<b>51</b>
Switch diagnostics . . . . .	51
Input power LED is extinguished . . . . .	51
System fault LED is illuminated. . . . .	52
Power-On self test diagnostics . . . . .	52
Heartbeat LED blink patterns . . . . .	52
Internal firmware failure blink pattern . . . . .	52
Fatal POST error blink pattern . . . . .	53
Configuration file system error blink pattern . . . . .	53
Over-temperature blink pattern . . . . .	53
Logged-in LED indications . . . . .	54
E_Port isolation. . . . .	54
Excessive port errors . . . . .	55
Transceiver diagnostics . . . . .	56
Power Supply Diagnostics . . . . .	56
Recovering a switch using maintenance mode . . . . .	57

Exiting the maintenance menu (option 0) . . . . .	58
Unpacking a firmware image file in maintenance mode (option 1). . . . .	58
Resetting the network configuration in maintenance mode (option 2) . . . . .	58
Resetting user accounts in maintenance mode (option 3). . . . .	58
Copying log files in maintenance mode (option 4) . . . . .	58
Removing the switch configuration in maintenance mode (option 5). . . . .	58
Remaking the file system in maintenance mode (option 6). . . . .	58
Resetting the switch in maintenance mode (option 7) . . . . .	59
Updating the boot loader in maintenance mode (option 8) . . . . .	59
<b>5 Removal/Replacement . . . . .</b>	<b>61</b>
Transceiver Removal and Replacement . . . . .	61
Power Supply Removal and Replacement. . . . .	61
<b>A Regulatory compliance and safety . . . . .</b>	<b>65</b>
Regulatory compliance . . . . .	65
Federal Communications Commission notice for Class A equipment. . . . .	65
Cables. . . . .	65
Laser device . . . . .	65
Laser safety warning . . . . .	65
Certification and classification information. . . . .	66
Laser product label . . . . .	66
International notices and statements . . . . .	66
Canadian notice (avis Canadien) . . . . .	66
European Union regulatory notice . . . . .	67
Japanese notice. . . . .	67
Korean notice . . . . .	67
Taiwan notice . . . . .	67
<b>B Electrostatic discharge . . . . .</b>	<b>69</b>
How to prevent electrostatic discharge . . . . .	69
Grounding methods . . . . .	69
<b>C Technical specifications. . . . .</b>	<b>71</b>
General specifications. . . . .	71
Maintainability features. . . . .	73
Fabric management specifications . . . . .	73
Weight and physical dimensions . . . . .	74
Electrical specifications . . . . .	74
Environmental requirements . . . . .	74
<b>D Factory configuration defaults . . . . .</b>	<b>75</b>
Factory switch configuration. . . . .	75
Factory port configuration . . . . .	76
Factory port threshold alarm configuration. . . . .	77
Factory zoning configuration . . . . .	77
Factory SNMP configuration . . . . .	78
Factory switch services configuration. . . . .	78
Factory DNS host name configuration . . . . .	79
Factory IP version 4 Ethernet configuration. . . . .	79
Factory IP version 6 Ethernet configuration. . . . .	80
Factory event logging configuration . . . . .	80
Factory NTP server configuration . . . . .	80
Factory timer configuration . . . . .	80
Factory RADIUS configuration . . . . .	81
Factory security configuration. . . . .	81
Factory Call Home configuration . . . . .	82
<b>Glossary . . . . .</b>	<b>83</b>
<b>Index . . . . .</b>	<b>87</b>

## Figures

1	SN6000 Fibre Channel Switch	11
2	Switch LEDs and controls	12
3	Fibre Channel ports	14
4	Port LEDs	15
5	Ethernet port	17
6	Serial port and pin identification	17
7	SN6000 Power Supplies	18
8	Two-switch stack	24
9	Three-switch stack	25
10	Four-switch stack	25
11	Five-switch stack	25
12	Six-switch stack	26
13	Attaching the rails to the switch	37
14	Installing the rear mounting brackets	37
15	Installing the switch and rail assembly	37
16	Fastening the rail to the front of the rack	38
17	Fastening the rail to the rear mounting bracket	38
18	Installing the filler panel	38
19	Management station and workstation cable connections	41
20	Switch LEDs	51
21	Logged-in LED	54
22	SN6000 Fibre Channel Switch Power Supply LEDs	56
23	Power Supply Removal	62
24	Power Supply Installation	63
25	Class 1 laser product label	66

## Tables

1	Document conventions	8
2	Fibre Channel port types	16
3	Serial port pin identification	18
4	Zoning database limits	22
5	Port-to-port latency	23
6	Management station requirements for Simple SAN Connection Manager	33
7	Workstation requirements for QuickTools	34
8	SN6000 Fibre Channel Switch rack mount kit hardware	36
9	General specifications	71
10	Maintainability features	73
11	Fabric management specifications	73
12	Switch physical dimensions	74
13	Electrical specifications	74
14	Environmental requirements	74
15	Switch configuration defaults	75
16	Port configuration defaults	76
17	Port threshold alarm configuration defaults	77
18	Zoning configuration defaults	77
19	SNMP configuration defaults	78
20	Services configuration defaults	78
21	DNS host name configuration defaults	79
22	IP version 4 Ethernet configuration defaults	79
23	IP version 6 Ethernet configuration defaults	80
24	Event logging configuration defaults	80
25	NTP server configuration defaults	80
26	Timer configuration defaults	80
27	RADIUS configuration defaults	81
28	Security configuration defaults	81
29	Call Home service configuration defaults	82

---

# About this guide

This guide provides information about:

- Becoming acquainted with the switch features and capabilities
- Planning a fabric including devices, device access, performance, multiple switch fabrics, switch services, fabric security, and fabric management.
- Installing and configuring an HP StorageWorks SN6000 Fibre Channel Switch
- Diagnosing and troubleshooting switch problems

## Intended audience

This manual introduces users to the switch and explains its installation and service. It is intended for users who are responsible for installing and servicing network equipment.

## Related documentation

In addition to this guide, see the following documents for this product:

- *HP StorageWorks SN6000 Fibre Channel Switch Quick Start Installation Instructions*
- *HP StorageWorks 8Gb Simple SAN Connection Kit Quick Start Instructions*
- *HP StorageWorks 8/20q and SN6000 Fibre Channel Switch Rack Mount Kit Quick Start Installation Instructions*
- *HP StorageWorks SN6000 Fibre Channel Switch QuickTools Switch Management User Guide*
- *HP StorageWorks SN6000 Fibre Channel Switch Command Line Interface Guide*
- *HP StorageWorks SN6000 Fibre Channel Switch Command Line Interface Quick Reference Guide*
- *HP StorageWorks Simple SAN Connection Manager User Guide*
- *HP StorageWorks 8/20q and SN6000 Fibre Channel Switch Event Message Reference Guide*
- *HP StorageWorks 8/20q and SN6000 Fibre Channel Switch Simple Network Management Protocol Reference Guide*
- *HP StorageWorks 8/20q and SN6000 Fibre Channel Switch CIM Agent Reference Guide*

For the latest product information, including firmware, documentation, and supported SAN configurations, see the following HP website: <http://www.hp.com/go/SN6000>.

# Document conventions and symbols

**Table 1** Document conventions

Convention	Element
Medium blue text: <a href="#">Figure 1</a>	Cross-reference links and e-mail addresses
Medium blue, underlined text ( <a href="http://www.hp.com">http://www.hp.com</a> )	Website addresses
<b>Bold font</b>	<ul style="list-style-type: none"><li>• Keys that are pressed</li><li>• Text typed into a GUI element, such as into a box</li><li>• GUI elements that are clicked or selected, such as menu and list items, buttons, and check boxes</li></ul>
<i>Italics font</i>	Text emphasis
Monospace font	<ul style="list-style-type: none"><li>• File and directory names</li><li>• System output</li><li>• Code</li><li>• Commands, their arguments, and argument values</li></ul>
<i>Monospace, italic font</i>	<ul style="list-style-type: none"><li>• Code variables</li><li>• Command-line variables</li></ul>
<b>Monospace, bold font</b>	Emphasis of monospace text, including file and directory names, system output, code, and text typed at the command line

---

 **WARNING!** Indicates that failure to follow directions could result in bodily harm or death.

---

 **CAUTION:** Indicates that failure to follow directions could result in damage to equipment or data.

---

 **IMPORTANT:** Provides clarifying information or specific instructions.

---

 **NOTE:** Provides additional information.

---

 **TIP:** Provides helpful hints and shortcuts.

---



## Rack stability

---

⚠ **WARNING!** To reduce the risk of personal injury or damage to equipment:

- Extend leveling jacks to the floor.
  - Ensure that the full weight of the rack rests on the leveling jacks.
  - Install stabilizing feet on the rack.
  - In multiple-rack installations, secure racks together.
  - Extend only one rack component at a time. Racks may become unstable if more than one component is extended.
- 

## HP technical support

Telephone numbers for worldwide technical support are listed on the HP support website:

<http://www.hp.com/support/>.

Collect the following information before calling:

- Technical support registration number (if applicable)
- Product serial numbers
- Product model names and numbers
- Applicable error messages
- Operating system type and revision level
- Detailed, specific questions

## Customer self repair

HP customer self repair (CSR) programs allow you to repair your StorageWorks product. If a CSR part needs replacing, HP ships the part directly to you so that you can install it at your convenience. Some parts do not qualify for CSR. Your HP authorized service provider will determine whether a repair can be accomplished by CSR.

For more information about CSR, contact your local service provider. For North America, see the CSR website:

<http://www.hp.com/go/selfrepair>

This product has no customer replaceable components.

## Product warranties

For information about HP StorageWorks product warranties, see the warranty information website:

<http://www.hp.com/go/storagewarranty>

## Subscription service

HP strongly recommends that customers sign up online using the Subscriber's choice website:

<http://www.hp.com/go/e-updates>.

- Subscribing to this service provides you with e-mail updates on the latest product enhancements, newest versions of drivers, and firmware documentation updates as well as instant access to numerous other product resources.
- After signing up, you can quickly locate your products by selecting **Business support** and then **Storage** under Product Category.

## HP websites

For other product information, see the following HP websites:

- <http://www.hp.com>
- <http://www.hp.com/go/storage>
- <http://www.hp.com/support/>
- <http://www.docs.hp.com>

## Documentation feedback

HP welcomes your feedback.

To make comments and suggestions about product documentation, please send a message to [storagedocs.feedback@hp.com](mailto:storagedocs.feedback@hp.com). All submissions become the property of HP.

# 1 General description

The HP StorageWorks SN6000 Fibre Channel Switch ([Figure 1](#)) is a 24 port, 8 Gb/s switch with both Ethernet and serial management interfaces. This section describes the features and capabilities of the HP StorageWorks SN6000 Fibre Channel Switch and includes information about the following features:

- [Switch LEDs and controls](#), page 12
- [Fibre Channel ports](#), page 14
- [Ethernet port](#), page 17
- [Power supplies and fans](#), page 18
- [Switch management](#), page 19

Fabrics are managed with the Command Line Interface (CLI) and the QuickTools web applet. You can also use the HP StorageWorks Simple SAN Connection Manager, which provides basic switch management functions, such as IP address configuration, and limited control of zoning.

- For more information about the CLI, see the *HP StorageWorks SN6000 Fibre Channel Switch Command Line Interface Guide*.
- For information about QuickTools, see the *HP StorageWorks SN6000 Fibre Channel Switch QuickTools Switch Management User Guide*.
- For information about Simple SAN Connection Manager, see the *HP StorageWorks Simple SAN Connection Manager User Guide*.

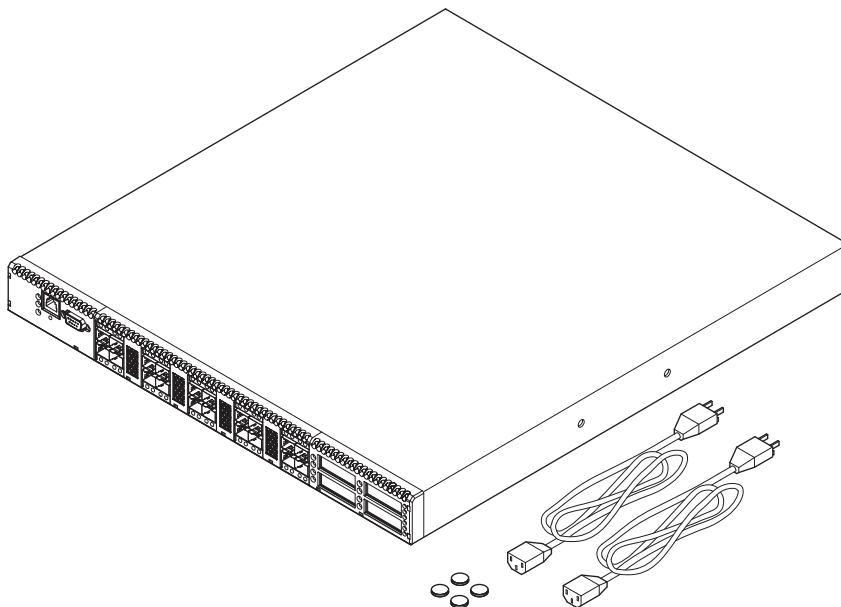

**Figure 1** SN6000 Fibre Channel Switch

## Switch LEDs and controls

The switch LEDs provide information about the switch's operational status. These LEDs include the Input Power LED (green), Heartbeat LED (green), and the System Fault LED (amber) (Figure 2). For information about port LEDs, see "Port LEDs" on page 15. The Maintenance button (Figure 2) is the only switch control. It is used to reset a switch or to recover a disabled switch. To apply power to the switch, plug the power cord into the switch AC power receptacle, located on the back of the switch, and into a 100–240 VAC power source.

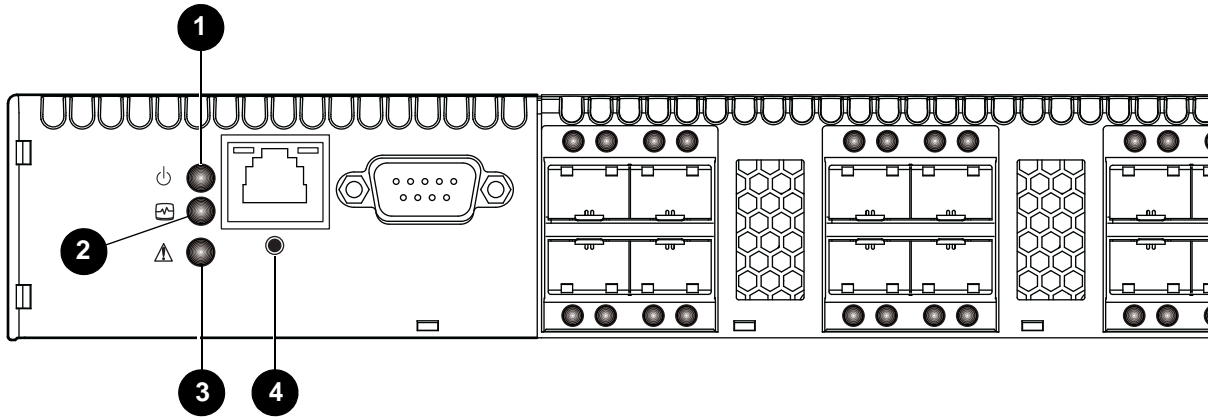

1 Input Power LED (green)

2 Heartbeat LED (green)

3 System Fault LED (amber)

4 Maintenance button

**Figure 2** Switch LEDs and controls

### Input power LED (green)

The Input Power LED indicates the voltage status at the switch logic circuitry. During normal operation, this LED illuminates to indicate that the switch logic circuitry is receiving the proper DC voltages. When the switch is in maintenance mode, this LED is extinguished.

### Heartbeat LED (green)

The Heartbeat LED indicates the status of the internal switch processor and the results of the POST. Following a normal power-up, the Heartbeat LED blinks about once per second to indicate that the switch passed the POST and that the internal switch processor is running. In maintenance mode, the Heartbeat LED illuminates continuously. For more information, see "Heartbeat LED blink patterns" on page 52.

### System fault LED (amber)

The System Fault LED illuminates to indicate that a fault exists in the switch firmware or hardware. Fault conditions include POST errors, over-temperature conditions, and power supply malfunctions. The Heartbeat LED shows a blink code for POST errors and over-temperature conditions. For more information, see "Heartbeat LED blink patterns" on page 52.

## Maintenance button

The Maintenance button (Figure 2) is a dual-function momentary switch on the front panel. Its purpose is to reset the switch or to place the switch in maintenance mode. Maintenance mode sets the IP address to 10.0.0.1 and provides access to the switch for maintenance purposes when flash memory or the resident configuration file is corrupted. For more information, see ["Recovering a switch using maintenance mode"](#) on page 57.

### Resetting a switch

To reset the switch, press and hold the Maintenance button with a pointed tool for less than 2 seconds. The switch will respond as follows:

1. All the switch LEDs will illuminate except the System Fault LED.
2. After approximately 1 minute, the power-on self test (POST) begins, extinguishing the Heartbeat LED.
3. When the POST is complete, the Input Power LED is illuminated and the Heartbeat LED is flashing once per second.

### Placing the switch in maintenance mode

To place the switch in maintenance mode:

1. Isolate the switch from the fabric.
2. Press and hold the Maintenance button with a pointed tool for a few seconds until only the Heartbeat LED (Figure 2) is illuminated. Continue holding the maintenance button until the Heartbeat LED goes off, then release the button. The Heartbeat LED illuminates continuously while the switch is in maintenance mode.

To exit maintenance mode and return to normal operation, press and release the Maintenance button momentarily to reset the switch.

## Fibre Channel ports

The HP StorageWorks SN6000 Fibre Channel Switch has 20 Fibre Channel Small Form-Factor Pluggable (SFP) ports and four Fibre Channel XPAK ports. SFP ports are numbered 0–19 (Figure 3). Each SFP port is served by an SFP optical transceiver and is capable of 1, 2, 4, or 8 Gb/s transmission. SFP ports are hot-pluggable and can self-discover both the port type and transmission speed when connected to devices or other switches. The port LEDs are located above ports 0–9 and below ports 10–19, and provide port login and activity status information.

The XPAK ports are numbered 20–23 (Figure 3). Each XPAK port is served by an XPAK optical transceiver or an XPAK switch stacking cable. An XPAK port is capable of 10 Gb/s (actual data transmission bandwidth 12.75 Gb/s) or 20 Gb/s (actual data transmission bandwidth 25.5 Gb/s) with the optional license key. XPAK ports are hot-pluggable and can self-discover transmission speed when connected to other switches. The XPAK switch stacking cable is a passive cable and transceiver assembly for connecting to other XPAK-capable switches. The XPAK ports come with covers that must be removed before installing transceivers or cables. XPAK port LEDs are located to the left of their respective ports and provide port login and activity status.

 **NOTE:** Setting a Fibre Channel port that has an 8 Gb/s SFP transceiver to 1 Gb/s downs the port.

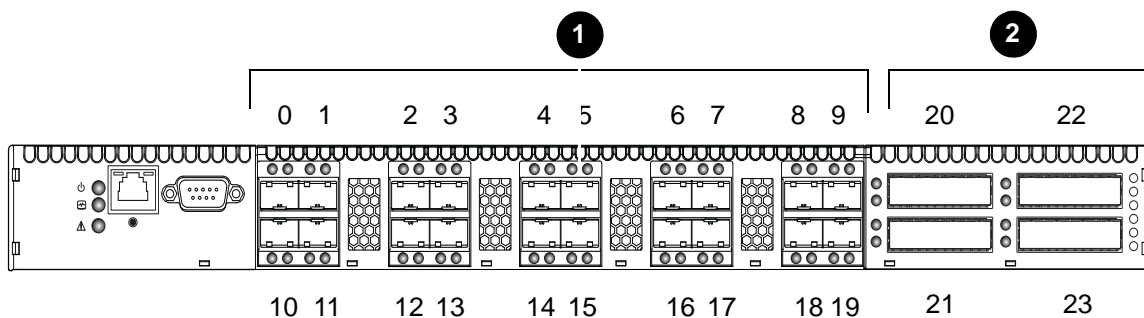

1 SFP ports

2 XPAK ports

**Figure 3** Fibre Channel ports

License keys are available from your authorized reseller to upgrade the XPAK ports to 20 Gb/s. For more information, see “[Installing feature license keys](#)” on page 46.

## Port LEDs

Each port has its own Logged-in LED (green) and Activity LED (green) (Figure 4).

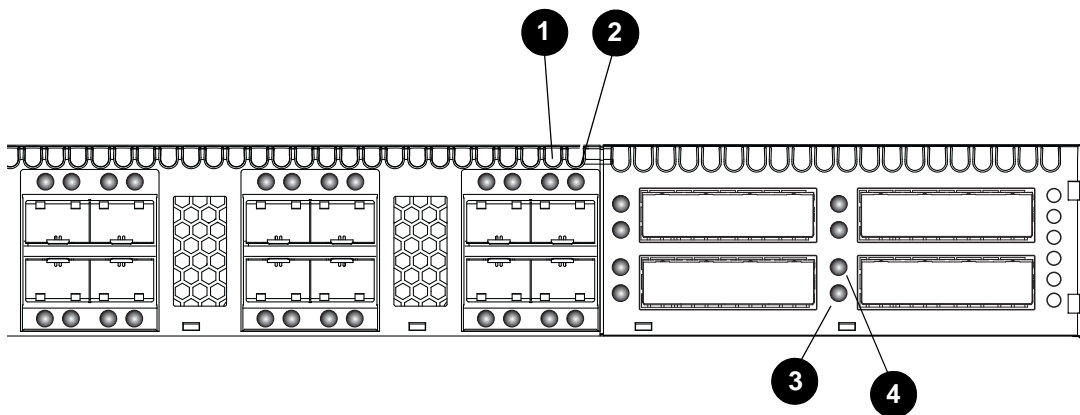

- |   |                        |   |                         |
|---|------------------------|---|-------------------------|
| 1 | Logged-in LED (port 9) | 2 | Activity LED (port 9)   |
| 3 | Activity LED (port 23) | 4 | Logged-in LED (port 23) |

**Figure 4** Port LEDs

### Port Logged-in LED (green)

The Logged-in LED indicates the logged-in or initialization status of the connected devices. After successful completion of the POST, the switch extinguishes all Logged-in LEDs. Following a successful port login, the switch illuminates the corresponding logged-in LED. This shows that the port is properly connected and able to communicate with its attached devices. The Logged-in LED remains illuminated as long as the port is initialized or logged in. If the port connection is broken or an error occurs that disables the port, the Logged-in LED is extinguished. For more information, see "[Logged-in LED indications](#)" on page 54.

### Port Activity LED (green)

The Activity LED indicates that data is passing through the port. Each frame that the port transmits or receives illuminates this LED for 50 milliseconds. This makes it possible to observe the transmission of a single frame.

## Transceivers

The HP StorageWorks SN6000 Fibre Channel Switch supports SFP optical transceivers for the SFP ports and XPAK optical transceivers or XPAK stacking cables for the XPAK ports. A transceiver converts electrical signals to and from optical laser signals to transmit and receive data. Duplex fiber optic cables plug into the SFP transceivers which then connect to the devices. An SFP port is capable of transmitting at 1-, 2-, 4-, or 8-Gb/s; however, the transceiver must also be capable of delivering at these rates.

The SFP and XPAK transceivers are hot-pluggable. This means that you can remove or install a transceiver while the switch is operating without harming the switch or the transceiver. However, communication with the connected device is interrupted. For information about installing and removing SFP+ optical transceivers, see "[Install the transceivers](#)" on page 39.

## Port types

The SN6000 Fibre Channel Switch supports generic ports (G\_Port, GL\_Port), fabric ports (F\_Port, FL\_Port), expansion ports (E\_Port), and transparent routing ports (TR\_Port). Switches come from the factory with all

SFP ports configured as GL\_Ports and all XPAK ports configured as G\_Ports. [Table 2](#) describes generic, fabric, expansion, and transparent routing port functions.

**Table 2** Fibre Channel port types

Port type	Description
GL_Port	Generic loop port—self-configures as an FL_Port when connected to a loop device, as an F_Port when connected to a single device, or as an E_Port when connected to another switch. If the device is a single device on a loop, the GL_Port will attempt to configure first as an F_Port, then if that fails, as an FL_Port.
G_Port	Generic port—self-configures as an F_Port when connected to a single device, or as an E_Port when connected to another switch.
FL_Port	Fabric loop port—supports a loop of up to 126 devices. An FL_Port can also configure itself during the fabric login process as an F_Port when connected to a single device (N_Port).
F_Port	Fabric port—supports a single device.
E_Port	Expansion port—expands the fabric by connecting SN6000 or 8/20q Fibre Channel switches. The SN6000 Fibre Channel Switch self-discovers all inter-switch connections. For more information, see " <a href="#">Multiple switch fabrics</a> " on page 23.
TR_Port	Transparent routing port—expands the fabric by connecting an SN6000 Fibre Channel Switch to an HP StorageWorks B-series or C-series remote fabric. The TR_Port provides transparent communication between local fabric devices and remote fabric devices while maintaining separate fabrics. For more information, see " <a href="#">Transparent routing</a> " on page 26.



## Ethernet port

The Ethernet port is an RJ-45 connector that provides a connection to a workstation through a 10/100 Base-T Ethernet cable (Figure 5). A workstation can be a Windows or a Linux server that is used to configure and manage the switch fabric. An Ethernet connection to the switch is required to manage the switch using the CLI, QuickTools, Simple SAN Connection Manager, or Simple Network Management Protocol (SNMP).

The Ethernet port has two LEDs: the Link Status LED (green) and the Activity LED (green). The Link Status LED illuminates continuously when an Ethernet connection has been established. The Activity LED illuminates when data is being transmitted or received over the Ethernet connection.

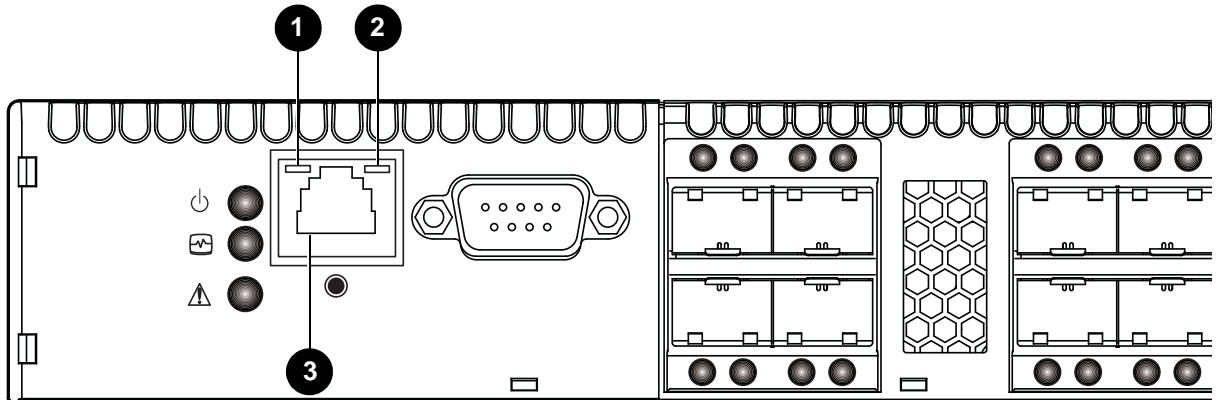

1 Activity LED

2 Link status LED

3 RJ-45 Ethernet port

Figure 5 Ethernet port

## Serial port

The SN6000 Fibre Channel Switch is equipped with an RS-232 serial port for maintenance purposes (Figure 6). You can manage the switch through the serial port using the CLI.

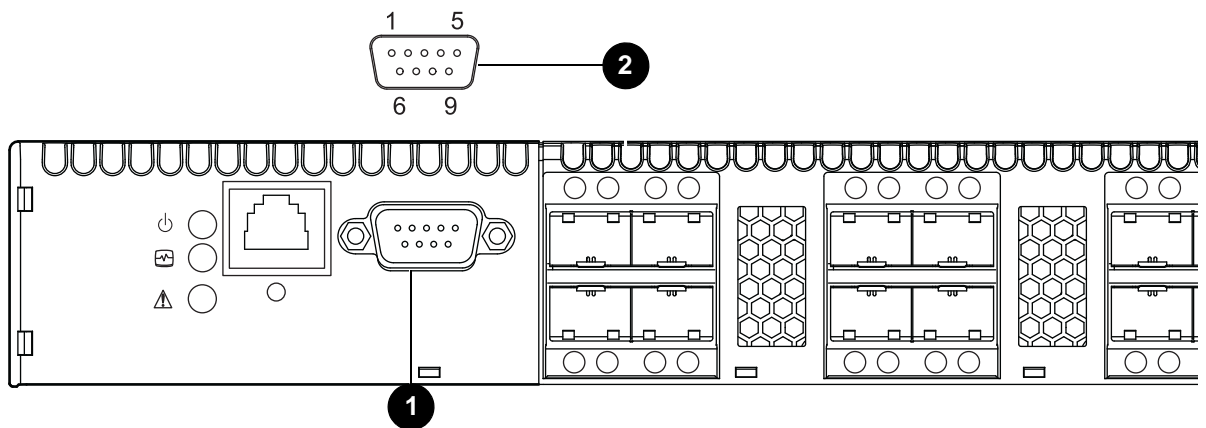

1 Serial port

2 RS-232 connector pin identification

Figure 6 Serial port and pin identification

The serial port connector requires a null-modem F/F DB9 cable. The pins on the switch RS-232 connector (Figure 6) are identified in Table 3. For information about connecting the workstation through the serial port, see “Connect the management station or workstation to the switch” on page 41.

**Table 3** Serial port pin identification

Pin Number	Description	Referred to as
1	Carrier Detect	DCD
2	Receive Data	RxD
3	Transmit Data (TxD)	TxD
4	Data Terminal Ready (DTR)	DTR
5	Signal Ground (GND)	GND
6	Data Set Ready (DSR)	DSR
7	Request to Send (RTS)	RTS
8	Clear to Send (CTS)	CTS
9	Ring Indicator (RI)	RI

## Power supplies and fans

The SN6000 Fibre Channel Switch - Single Power Supply has a single power supply that converts 100–240 VAC to DC voltages for the various switch circuits. Internal fans provide cooling. The switch monitors internal air temperature, and therefore does not monitor or report fan operational status. Air flow is front-to-back. To energize the switch, plug the power cord into the switch AC receptacle and into a 100–240 VAC power source.

The SN6000 Fibre Channel Switch - Dual Power Supply has two hot-pluggable power supplies that convert standard 100–240 VAC to DC voltages for the various switch circuits. Each power supply has an AC power receptacle and two status LEDs (Figure 7):

- The Power Supply Status LED (green) illuminates to indicate that the power supply is receiving AC voltage and producing the proper DC voltages.
- The Power Supply Fault LED (amber) illuminates to indicate that a power supply fault exists and requires attention.

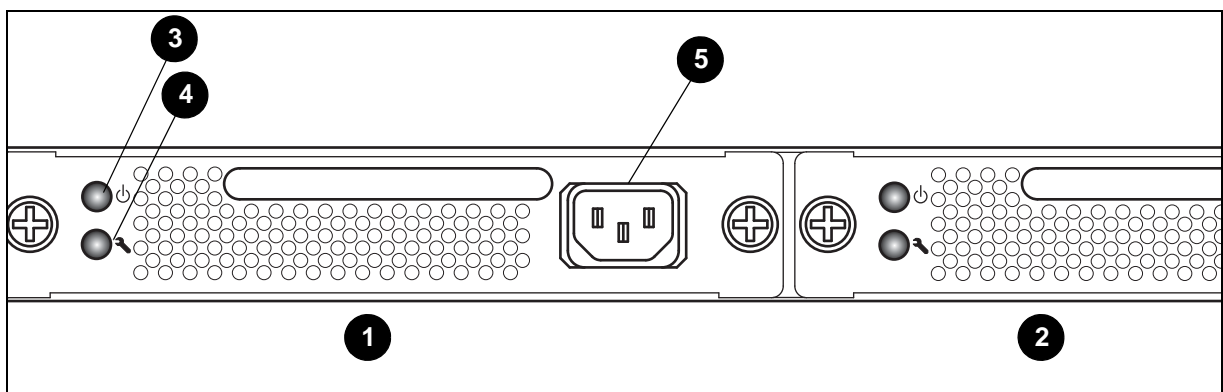

- 1 Power supply 1
- 2 Power supply 2
- 3 Status LED (green)
- 4 Fault LED (amber)
- 5 AC power receptacle

**Figure 7** SN6000 Power Supplies

Each power supply is capable of providing all of the switch's power needs. During normal operation, each power supply provides half of the demand. If one power supply goes offline, the second power supply steps up and provides the difference.

The power supplies are hot-pluggable and interchangeable. Hot-pluggable means that you can remove and replace one power supply while the switch is in operation without disrupting service. See "[Transceiver Removal and Replacement](#)" on page 61 for information about replacing the power supplies.

Connecting a power supply to an AC voltage source energizes the switch logic circuitry. Internal fans provide cooling. Air flow is front-to-back.

## Switch management

The switch supports the following management tools and protocols:

- [QuickTools web applet](#), page 19
- [Simple SAN Connection Manager](#), page 19
- [Command line interface](#), page 19
- [Simple Network Management Protocol](#), page 20
- [Storage Management Initiative–Specification \(SMI-S\)](#), page 20
- [File transfer protocols](#), page 20

## QuickTools web applet

QuickTools is a browser-based graphical user interface (GUI) that provides switch management capabilities beyond those of Simple SAN Connection Manager. You run QuickTools by opening the switch IP address with an internet browser on your workstation. See the *HP StorageWorks SN6000 Fibre Channel Switch QuickTools Switch Management User Guide*. QuickTools provides the following management features:

- Faceplate device management
- Switch stack management
- Switch and port statistics
- Configuration wizard
- Zoning administration
- Fabric tree for fabric management
- User account configuration
- Switch and fabric events
- Operational and environmental statistics
- Global device nicknames
- Inband management of other switches in the fabric
- Online help

## Simple SAN Connection Manager

HP StorageWorks Simple SAN Connection Manager is a GUI-based management application for HP StorageWorks that runs on a workstation known as the management station. It provides basic automated configuration and management of switches, HBAs, and storage devices. Simple SAN Connection Manager version 3.0 or later is required for the HP SN6000 Fibre Channel Switch.

## Command line interface

The command line interface (CLI) provides monitoring and configuration functions by which the administrator can manage the fabric and its switches. The CLI is available over an Ethernet connection or a serial connection. For more information, see the *HP StorageWorks SN6000 Fibre Channel Switch Command Line Interface Guide*.

## Simple Network Management Protocol

SNMP provides monitoring and trap functions for the fabric. The switch firmware supports SNMP versions 1, 2, and 3, the Fibre Alliance Management Information Base (FA-MIB) version 4.0, and the Fabric Element Management Information Base (FE-MIB) RFC 2837. Traps can be formatted using SNMP version 1 or 2. SNMP version 3 provides secure access to devices through a combination of authentication and encryption. You can enable SNMP, configure SNMP traps, and configure SNMP version 3 security using the command line interface or QuickTools.

## Storage Management Initiative–Specification (SMI-S)

SMI-S provides for the management of the switch through third-party applications that use the SMI-S. For more information, see the *HP StorageWorks 8/20q and SN6000 Fibre Channel Switch CIM Agent Reference Guide*.

## File transfer protocols

FTP and TFTP provide the command line interface for exchanging files between the switch and the workstation. These files include firmware image files, configuration files, and log files. For more information about FTP and TFTP, see the *HP StorageWorks SN6000 Fibre Channel Switch Command Line Interface Guide*.

---

## 2 Planning

Consider the following when planning a fabric:

- [Devices](#), page 21
- [Device access](#), page 21
- [Performance](#), page 22
- [Feature licenses](#), page 23
- [Multiple switch fabrics](#), page 23
- [Switch services](#), page 28
- [Security](#), page 30
- [Fabric management](#), page 32

### Devices

When planning a fabric, consider the following:

- The number of devices and the anticipated demand. This will determine the number of ports that are needed and in turn the number of switches.
- The transmission speeds of your HBAs, SFPs, and XPAKs. The switch supports 2 Gb/s, 4 Gb/s and 8 Gb/s transmission speeds with SFPs. The transmission speed for XPAKs is 10 Gb/s or 20 Gb/s when enabled by installation of the SN6000 Stackable 20Gb ISL Upgrade LTU.

---

 **IMPORTANT:** Setting a Fibre Channel port that has an 8 Gb/s SFP transceiver to 1 Gb/s downs the port.

---

- The distribution of targets and initiators. An F\_Port supports a single device. An FL\_Port can support up to 126 devices in an arbitrated loop.

### Device access

Consider device access needs within the fabric. Access is controlled by the use of zoning. Some zoning strategies include the following:

- Separating devices by operating system
- Separating devices that have no need to communicate with other devices in the fabric or have classified data
- Separating devices into department, administrative, or other functional group

Zoning divides the fabric for purposes of controlling discovery and inbound traffic. A zone is a named group of ports or devices. Members of the same zone can communicate with each other and transmit outside the zone, but cannot receive inbound traffic from outside the zone. Zoning is hardware-enforced only when a port/device is a member of no more than eight zones whose combined membership does not exceed 64. If this condition is not satisfied, that port behaves as a soft zone member. You can assign ports/devices to a zone individually or as a group by creating an alias.

A zone can be a component of more than one zone set. Several zone sets can be defined for a fabric, but only one zone set can be active at one time. The active zone set determines the current fabric zoning.

A zoning database is maintained on each switch. [Table 4](#) describes the zoning database limits, excluding the active zone set.

**Table 4** Zoning database limits

Limit	Description
MaxZoneSets	Maximum number of zone sets (256).
MaxZones	Maximum number of zones (2,000).
MaxAliases	Maximum number of aliases (2,500).
MaxTotalMembers	Maximum number of zone and alias members (10,000) that can be stored in the zoning database. Each instance of a zone member or alias member counts toward this maximum.
MaxZonesInZoneSets	Maximum number of zones that are components of zone sets (2,000), excluding the orphan zone set. Each instance of a zone in a zone set counts toward this maximum.
MaxMembersPerZone	Maximum number of members in a zone (2,000).
MaxMembersPerAlias	Maximum number of members in an alias (2,000)

## Performance

The SN6000 Fibre Channel Switch supports class 2 and class 3 Fibre Channel service at transmission rates of 8 Gb/s with a maximum frame size of 2,148 bytes. Related performance characteristics include the following:

- [Distance](#), page 22
- [Bandwidth](#), page 22
- [Latency](#), page 23

## Distance

Consider the physical distribution of devices and switches in the fabric. Choose SFP transceivers that are compatible with the cable type, distance, Fibre Channel revision level, and the device host bus adapter. For more information about cable types and transceivers, see ["Technical specifications"](#) on page 71.

Each Fibre Channel port is supported by a data buffer with a 16 credit capacity; that is, 16 maximum sized frames. For fibre optic cables, this enables full bandwidth over approximately 3 kilometers at 8 Gb/s (4.8 credits/km).

## Bandwidth

Bandwidth is a measure of the volume of data that can be transmitted at a given transmission rate. An SFP port can transmit or receive at nominal rates of 1, 2, 4, or 8 Gb/s depending on the device to which it is connected. This corresponds to full duplex bandwidth values of 212 MB, 424 MB, 850 MB, and 1700 MB respectively. XPAK ports transmit at a nominal rate of 10 Gb/s which corresponds to a full duplex bandwidth value of 2550 MB. With an SN6000 Stackable 20Gb ISL Upgrade LTU, XPAK ports can transmit at a nominal rate of 20 Gb/s (5100 MB bandwidth)

Multiple source ports can transmit to the same destination port if the destination bandwidth is greater than or equal to the combined source bandwidth. For example, two 2 Gb/s source ports can transmit to one 4 Gb/s destination port. Similarly, one source port can feed multiple destination ports if the combined destination bandwidth is greater than or equal to the source bandwidth.

In multiple chassis fabrics, each link between chassis contributes 424, 850, 1700, 2550 or 5100 megabytes of bandwidth between those chassis, depending on the speed of the link. When additional bandwidth is needed between devices, increase the number of links between the connecting switches. The switch guarantees in-order delivery with any number of links between chassis.

## Latency

Latency is a measure of how fast a frame travels through a switch from one port to another. The factors that affect latency include transmission rate and the source/destination port relationship (Table 5).

**Table 5** Port-to-port latency

Source Rate	Destination Rate					
	Gb/s	2	4	8	10	20
2		< 0.6 $\mu$ sec	< 0.7 $\mu$ sec <sup>1</sup>	< 0.6 $\mu$ sec <sup>1</sup>	< 0.6 $\mu$ sec <sup>1</sup>	< 0.6 $\mu$ sec <sup>1</sup>
4		< 0.4 $\mu$ sec	< 0.3 $\mu$ sec	< 0.4 $\mu$ sec <sup>1</sup>	< 0.4 $\mu$ sec <sup>1</sup>	< 0.3 $\mu$ sec <sup>1</sup>
8		< 0.3 $\mu$ sec	< 0.2 $\mu$ sec	< 0.2 $\mu$ sec	< 0.2 $\mu$ sec <sup>1</sup>	< 0.2 $\mu$ sec <sup>1</sup>
10		< 0.3 $\mu$ sec	< 0.3 $\mu$ sec	< 0.2 $\mu$ sec	< 0.2 $\mu$ sec	< 0.2 $\mu$ sec <sup>1</sup>
20		< 0.3 $\mu$ sec	< 0.2 $\mu$ sec	< 0.2 $\mu$ sec	< 0.2 $\mu$ sec	< 0.2 $\mu$ sec

<sup>1</sup> Based on minimum frame size of 36 bytes. Latency increases for larger frame sizes.

## Feature licenses

A license key provides a way to expand the capabilities of your switch and fabric as your needs grow. The HP StorageWorks SN6000 Stackable 20Gb ISL Upgrade LTU enables the XPAK ports to transmit at 20 Gb/s instead of the default 10 Gb/s. Applying a license key is not disruptive, nor does it require a switch reset. To order a license key, contact your switch distributor or your authorized reseller. For more information, see “Installing feature license keys” on page 46.

## Multiple switch fabrics

By connecting switches to one another, you can expand the number of available ports for devices. Each switch in the fabric is identified by a unique domain ID, and the fabric can automatically resolve domain ID conflicts. Because the Fibre Channel ports are self-configuring, you can connect SN6000 Fibre Channel Switches together in a wide variety of topologies. When planning your fabric, consider your topology and cabling requirements. Transparent routing to a legacy fabric is also possible using TR\_Ports.

For more information about Storage Area Network (SAN) connectivity, see the *SAN Design Reference Guide* available at the HP website: <http://www.hp.com/go/SANdesignguide>.

The following topics describe important aspects of multiple switch fabrics:

- [Optimizing device performance](#), page 23
- [Domain ID, principal priority, and domain ID lock](#), page 24
- [Common topologies](#), page 26
- [Transparent routing](#), page 26

## Optimizing device performance

When choosing a topology for a multiple switch fabric, you should also consider the proximity of your server and storage devices and the performance requirements of your application. Storage applications such as video distribution, medical record storage/retrieval, or real-time data acquisition can have specific latency or bandwidth requirements.

The SN6000 Fibre Channel Switch provides the lowest latency of any product in its class. For information about latency, see “Performance” on page 22. However, the highest performance is achieved on Fibre Channel switches by keeping traffic within a single switch instead of relying on ISLs. Therefore, for optimal device performance, place devices on the same switch under the following conditions:

- Heavy I/O traffic between specific server and storage devices.
- Distinct speed mismatch between devices such as the following:
  - An 8 Gb/s server and a slower 4 Gb/s storage device
  - A high performance server and a slow tape storage device

## Domain ID, principal priority, and domain ID lock

The following switch configuration settings affect multiple switch fabrics:

- Domain ID
- Principal priority
- Domain ID lock

The domain ID is a unique number from 1–239 that identifies each switch in a fabric. The principal priority is a number (1–255) that determines the principal switch which manages domain ID assignments for the fabric. The switch with the highest principal priority (1 is high, 255 is low) becomes the principal switch. If the principal priority is the same for all switches in a fabric, the switch with the lowest Worldwide Name (WWN) becomes the principal switch.

The domain ID lock allows (False) or prevents (True) the reassignment of the domain ID on that switch. Switches come from the factory with the domain ID set to 1, the domain ID lock set to False, and the principal priority set to 254. For information about changing the default domain ID, domain ID lock, and principal priority parameters, see the `set config switch` command in the *HP StorageWorks SN6000 Fibre Channel Switch Command Line Interface Guide*.

If you connect a new switch to an existing fabric with its domain ID unlocked, and a domain ID conflict occurs, the new switch will isolate as a separate fabric. You can remedy this by resetting the new switch or taking it offline then putting it back online. The principal switch will reassign the domain ID and the switch will join the fabric.

---

 **NOTE:** Domain ID reassignment is not reflected in zoning that is defined by domain ID/port number pair or Fibre Channel address. You must reconfigure zones that are affected by domain ID reassignment. To prevent zoning definitions from becoming invalid under these conditions, lock the domain IDs. Domain ID reassignment has no effect on zone members defined by WWN.

---

## Stacking

You can connect up to six HP StorageWorks SN6000 Fibre Channel Switches together through the XPAK ports, thus preserving the SFP ports for devices. This is called stacking. The following 2-, 3-, 4-, 5-, and 6-switch stacking configurations are recommended for best performance and redundancy. Each XPAK port contributes 12.75 GB of bandwidth between chassis in each direction. This is equivalent to three SFP connections operating at 4 Gb/s. If you upgrade the XPAK ports to 20 Gb/s, this is equivalent to three SFP connections operating at 8 Gb/s. [Figure 8](#) shows a two-switch stack of model SN6000 switches using two 3-inch XPAK switch stacking cables.

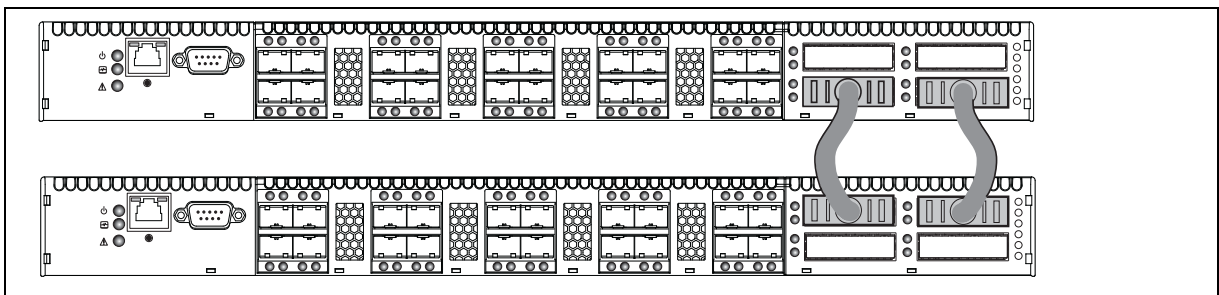

**Figure 8** Two-switch stack



Figure 9 shows a three-switch stack of HP StorageWorks SN6000 Fibre Channel Switch switches using two 3-inch and one 9-inch XPAK switch stacking cables. 60 SFP ports are available for devices.

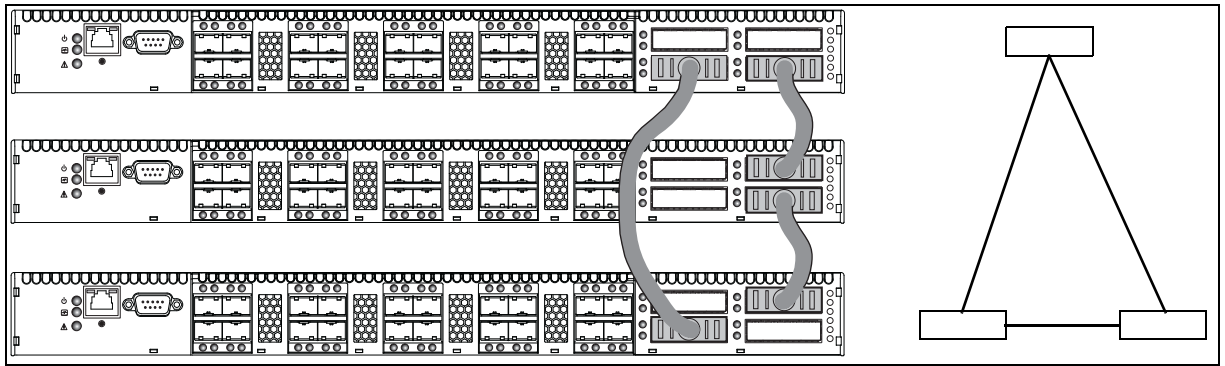

Figure 9 Three-switch stack

Figure 10 shows a four-switch stack of model SN6000 switches using three 3-inch and three 9-inch XPAK switch stacking cables. 80 SFP ports are available for devices.

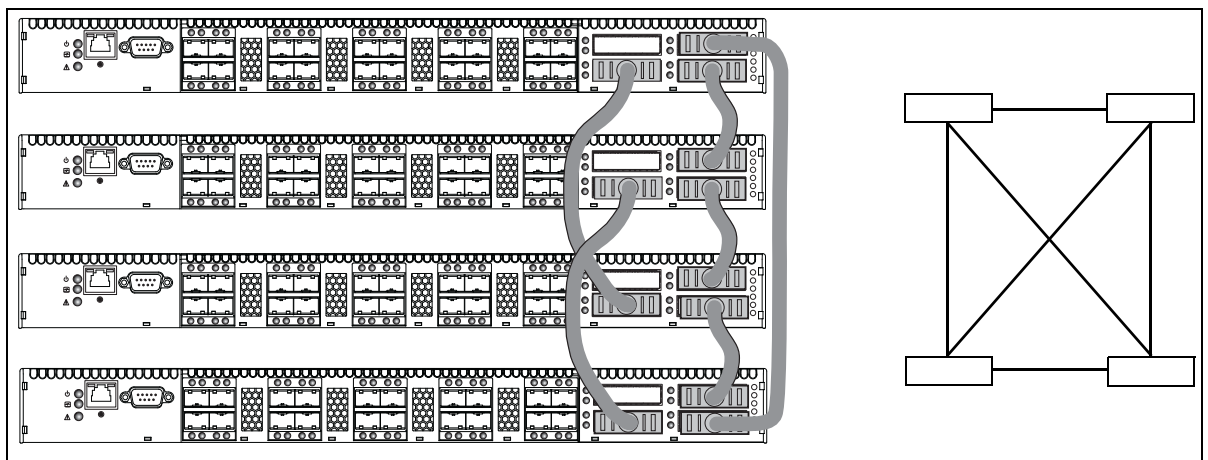

Figure 10 Four-switch stack

Figure 11 shows a five-switch stack of model SN6000 switches using ten XPAK switch stacking cables. 100 SFP ports are available for devices.

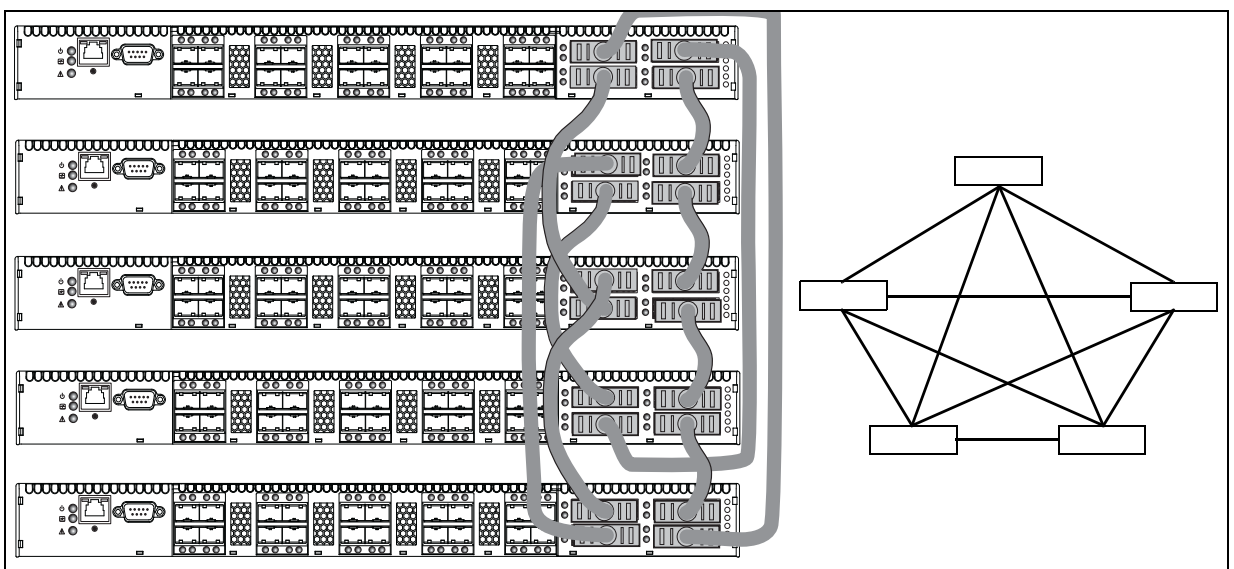

Figure 11 Five-switch stack

Figure 12 shows a six-switch stack of model SN6000 switches using eight XPAK switch stacking cables. 120 SFP ports are available for devices.

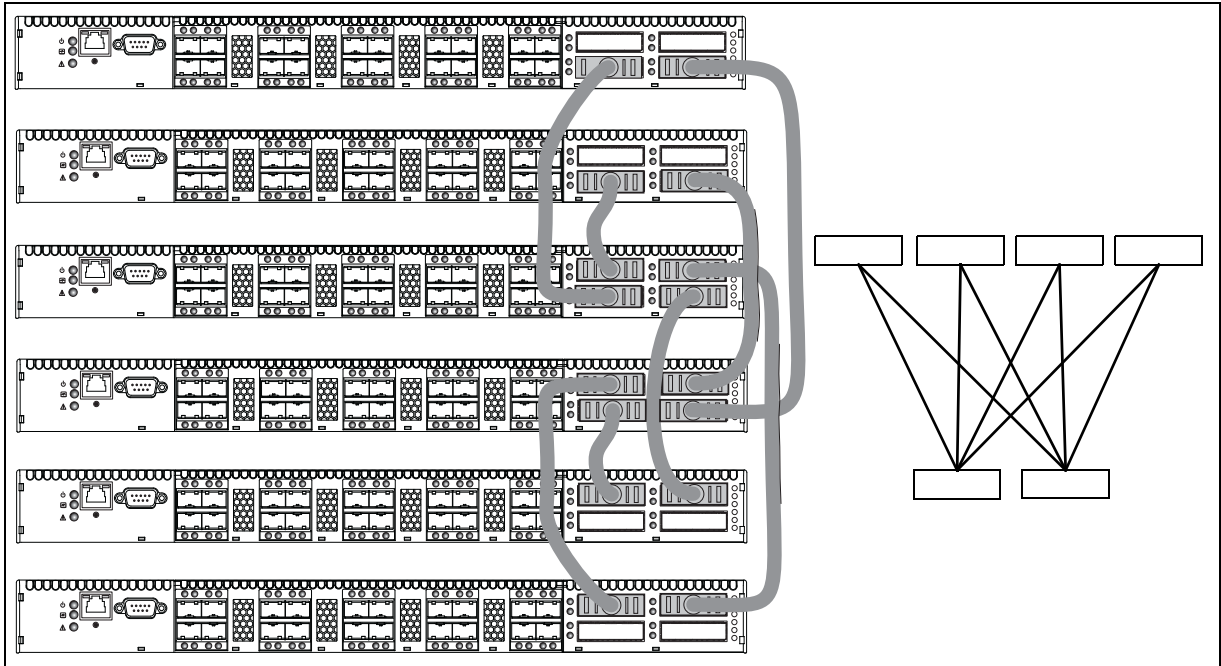

Figure 12 Six-switch stack

## Common topologies

Although HP recommends using the XPAK stacking ports to achieve the highest cabling efficiency and bandwidth, you can also create multiple switch configurations using the SFP ports. The HP StorageWorks SN6000 Fibre Channel Switch switch supports the following topologies using the SFP ports:

- Cascaded fabric topology
- Ring fabric topology
- Meshed fabric topology
- Core-edge fabric topology

For additional information about topologies and Storage Area Network (SAN) connectivity, see the *SAN Design Reference Guide* available at the HP website: <http://www.hp.com/go/SANdesignguide>.

## Transparent routing

**IMPORTANT:** The Simple SAN Connection Manager (SSCM) application can manage SN6000 Fibre Channel Switches with active TR\_Ports; however, SSCM cannot manage or discover remote switches or devices in the remote fabric. Use QuickTools and the storage management interface to present Logical Unit Numbers (LUNs) to remote devices. SSCM displays the remote fabric as a grayed-out switch, and no management can be performed. SSCM version 3.0 or later is required for the HP SN6000 Fibre Channel Switch. SSCM version 2.0 and earlier versions do not support the management of fabrics that include switches with active TR\_Ports and may disrupt communication between an SN6000 or 8/20q Fibre Channel Switch and the remote fabric.

The transparent routing feature provides inter-fabric routing to allow controlled and limited access between devices on a SN6000 Fibre Channel Switch (local) fabric and devices on a remote fabric consisting of B-series or C-series switches. For a list of switches that are supported in a remote fabric, see the *HP StorageWorks SN6000 Fibre Channel Switch Release Notes*, and the *HP StorageWorks SAN Design Reference Guide* on the HP website: <http://www.hp.com/go/sandesignguide>. This type of inter-fabric connection uses the Fibre Channel industry N-Port ID Virtualization (NPIV), and makes local and remote devices accessible to each other while maintaining the local and remote fabrics as separate fabrics.

You can connect multiple SN6000 Fibre Channel Switches to one or more remote fabrics using multiple TR\_Ports. Local and remote devices are identified by their respective port worldwide names. Consider the following mapping rules:

- A TR\_Port can support a maximum of 32 local device/remote device mappings.
- A specific local device can be mapped to devices on only one remote fabric. Local devices on the same SN6000 Fibre Channel Switch can each be mapped to different remote fabrics.
- For mappings between a specific SN6000 Fibre Channel Switch and a remote fabric, each local device or remote device can be mapped over only one TR\_Port. Additional mappings to either device must use that same TR\_Port.
- Multiple local devices connected to different local switches can be mapped to the same remote device over one TR\_Port on each local switch.
- A local device cannot be mapped over an E\_Port to another local switch, then over a TR\_Port to the remote device. The local switch to which the local device is connected must connect directly to the remote fabric over a TR\_Port.

---

 **NOTE:** When a local device is mapped over a TR\_Port to a remote device, the local device and its TR\_Port appear as an NPIV connected device in the remote fabric. It is possible, though not recommended, to map such a local device over a second TR\_Port to a local device in a second local fabric. In this case, if you merge the two local fabrics, the transparent route becomes inactive for the devices that now have a path over an ISL, and an alarm is generated.

---

You can configure transparent routing using QuickTools or the CLI, though QuickTools is recommended because it validates your entries, manages the zone mapping for the local fabric, and creates a list of zoning commands that can be run in a script on a HP StorageWorks B-series or C-series SAN switch. For more detailed information, see the *HP StorageWorks SN6000 Fibre Channel Switch QuickTools Switch Management User Guide* and the *HP StorageWorks SN6000 Fibre Channel Switch Command Line Interface Guide*.

---

**IMPORTANT:** Since C-series switches do not support the Unzoned Name Server, C-series fabrics must be “pre-zoned” before you can set up TR mappings to a remote C-series fabric using the TR Mapping Manager dialog box. The C-series fabric zoneset must be changed to add zones so that the WWNs of the remote devices to be mapped and the WWNs of the SN6000 Fibre Channel Switch TR ports are zoned together. For more information, see the C-series documentation for specific information to configure zoning. Retain these zones in the zoneset after completion of the TR mapping as a best practice, until you no longer need to map the device to the local fabric.

---

To configure transparent routing using QuickTools:

1. Determine what devices on the local fabric require access to devices on the remote fabric. Local devices must be attached directly to the SN6000 Fibre Channel Switch.
2. Configure one or more TR\_Ports on the local SN6000 Fibre Channel Switch first and then connect the TR\_Port to the remote fabric. QuickTools prompts you to configure TR\_Ports where existing port connections to remote fabrics have isolated. For remote HP StorageWorks B-series or C-series fabrics, the switch to which the TR\_Port connects must support N-Port ID Virtualization (NPIV) and for B-series fabrics the interoperability mode must be configured to InteropMode=0. Other B-series or C-series switches in the remote fabric need not support NPIV.

---

**NOTE:** Be sure to configure the TR\_Port before connecting the remote fabric to the HP StorageWorks SN6000 Fibre Channel Switch. If the remote fabric is connected to a port on the HP StorageWorks SN6000 Fibre Channel Switch that is not a TR\_Port, the two fabrics may establish an E\_Port connection and the local and remote fabrics may merge. This mixed fabric is not a supported configuration. If the port type is changed to TR\_Port after connecting the remote fabric, a port reset may be required to completely establish the TR connection.

---

3. Map local devices to remote devices and activate the connection. The QuickTools mapping process creates an inter-fabric zone (IFZ) in the active zone set consisting of the local device, the remote device, and the TR\_Port. When the mapping is complete, QuickTools activates the new zone set.  
The name of the inter-fabric zone begins with IFZ followed by the lowest device port WWN followed by the remaining port WWN, all uppercase, separated by underscores (\_). For example, consider the following local and remote device WWNs:
  - Local device: 21:00:00:e0:8b:0e:d3:59
  - Remote device: 22:00:00:04:cf:a8:7f:2d
 The inter-fabric zone name would be:
 

```
IFZ_210000E08B0ED359_22000004CFA87F2D
```
4. Apply the same inter-fabric zone that was created on the local fabric to the active zoning on the remote fabric. QuickTools creates a suggested list of commands during the mapping process that, when run on a remote fabric consisting of HP StorageWorks B-series or C-series switches, will make the necessary zoning changes to the remote fabric. See the *HP StorageWorks SN6000 Fibre Channel Switch QuickTools Switch Management User Guide* for important details on creating and using this list of suggested commands. When modifications to the active zoning on both fabrics are complete, the transparent routing connection becomes active, and the local devices will discover the remote devices.

## Switch services

You can configure your switch to suit the demands of your environment by enabling or disabling a variety of switch services. Familiarize yourself with the following switch services and determine which ones you need.

- **Telnet:** Provides for the management of the switch over a Telnet connection. Disabling this service is not recommended. The default is `enabled`.
- **Secure Shell (SSH):** Provides for secure remote connections to the switch using SSH. Your workstation must also use an SSH client. The default is `disabled`.
- **GUI Management:** Provides for out-of-band management of the switch with Simple SAN Connection Manager, QuickTools, SNMP, and SMI-S. If this service is disabled, the switch can only be managed inband or through the serial port. The default is `enabled`.
- **Inband Management:** Provides for the management of the switch over an inter-switch link using Simple SAN Connection Manager, QuickTools, SNMP, or management server. If you disable inband management, you can no longer communicate with that switch by means other than an Ethernet or serial connection. The default is `enabled`.
- **Secure Socket Layer (SSL):** Provides for secure SSL connections for the QuickTools web applet and SMI-S. This service must be enabled to authenticate users through a Remote Authentication Dial-in Service (RADIUS) server. To enable secure SSL connections, you must first synchronize the date and time on the switch and the workstation. Enabling SSL automatically creates a security certificate on the switch. The default is `disabled`.
- **QuickTools web applet (EmbeddedGUI):** Provides for access to the QuickTools web applet. QuickTools enables you to point at a switch with an internet browser and manage the switch through the browser. The default is `enabled`.
- **Simple Network Management Protocol (SNMP):** Provides for the management of the switch through third-party applications that use the Simple Network Management Protocol (SNMP). Security consists of a read community string and a write community string that serve as passwords that control read and write access to the switch. These strings are set at the factory to these well-known defaults and should be changed if SNMP is to be enabled. Otherwise, you risk unwanted access to the switch. The switch supports SNMP versions 1, 2, and 3. The default configuration enables SNMP and disables SNMP version 3 security.
- **Common Information Model (CIM):** Provides for the management of the switch through third-party applications that use the Storage Management Initiative–Specification (SMI-S). The default is `enabled`.
- **File Transfer Protocol (FTP):** Provides for transferring files rapidly between the workstation and the switch using FTP. The default is `enabled`.
- **Management Server (MS):** Enables or disables the management of the switch through third-party applications that use FC-GS-3 Management Server. The default is `disabled`.

- **Call Home:**

---

 **IMPORTANT:** The Call Home service provides an e-mail notification capability for the switch. This service has no relationship with the HP Call Home feature, which notifies only HP services.

---

Provides for automated e-mail notification of switch status and operating conditions based on specified event severity levels. The default is `enabled`. The Call Home service requires an Ethernet connection to at least one Simple Mail Transfer Protocol (SMTP) server. You must configure the Call Home service to do the following:

- Enable primary and secondary SMTP servers and specify their IP addresses
- Specify contact information

Configure one or more Call Home profiles to specify e-mail recipients, message format, and the event severity level that will initiate a message. In addition, you can configure periodic event data collection and processing through the `Tech_Support_Center` profile for automated status and trend analysis.

# Security

Security is available at the following levels:

- [User account security](#), page 30
- [IP security](#), page 30
- [Port binding](#), page 30
- [Connection security](#), page 30
- [Device security](#), page 31

## User account security

User account security consists of the administration of account names, passwords, expiration date, and authority level. If an account has Admin authority, all management tasks can be performed by that account in the CLI, QuickTools, and Simple SAN Connection Manager. Otherwise only monitoring tasks are available. The default account name, Admin, is the only account that can create or add account names and change passwords of other accounts. All users can change their own passwords. Account names and passwords are always required when connecting to a switch.

Authentication of the user account and password can be performed locally using the switch's user account database or it can be done remotely using a RADIUS server such as Microsoft RADIUS. Authenticating user logins on a RADIUS server requires a secure management connection to the switch. For information about securing the management connection, see "[Connection security](#)" on page 30. A RADIUS server can also be used to authenticate devices and other switches as described in "[Device security](#)" on page 31.

Consider your management needs and determine the number of user accounts, their authority needs, and expiration dates. Also consider the advantages of centralizing user administration and authentication on a RADIUS server. Use the CLI to configure RADIUS servers. For more information about RADIUS server configuration, see the *HP StorageWorks SN6000 Fibre Channel Switch Command Line Interface Guide*.

---

 **NOTE:** If the same user account exists on a switch and its RADIUS server, that user can login with either password, but the authority and account expiration will always come from the switch database.

---

## IP security

IP Security provides encryption-based security for IP version 4 and IP version 6 communications through the use of security policies and associations. Policies can define security for host-to-host, host-to-gateway, and gateway-to-gateway connections; one policy for each direction. For example, to secure the connection between two hosts, you need two policies: one for outbound traffic from the source to the destination, and another for inbound traffic to the source from the destination.

A security association defines which encryption algorithm and encryption key to apply when called by a security policy. A security policy may call several associations at different times, but each association is related to only one policy. When planning IP security, consider the connections to be secured and the encryption methods to be used.

## Port binding

Port binding provides authorization for a list of up to 32 switch and device WWNs that are permitted to log in to a particular switch port. Switches or devices that are not among the 32 are refused access to the port. Consider what ports to secure and the set of switches and devices that are permitted to log in to those ports. Use the CLI to configure port binding. For more information about port binding configuration, see the *HP StorageWorks SN6000 Fibre Channel Switch Command Line Interface Guide*.

## Connection security

Connection security provides an encrypted data path for switch management methods. The switch supports the Secure Shell (SSH) protocol for the command line interface and the Secure Socket Layer (SSL) protocol for management applications such as QuickTools and SMI-S. Use the CLI to configure SSH and SSL. For more information about SSH and SSL configuration, see the *HP StorageWorks SN6000 Fibre Channel Switch Command Line Interface Guide*.



The SSL handshake process between the workstation and the switch involves the exchanging of certificates. These certificates contain the public and private keys that define the encryption. When the SSL service is enabled, a certificate is automatically created on the switch. The workstation validates the switch certificate by comparing the workstation date and time to the switch certificate creation date and time. For this reason, it is important to synchronize the workstation and switch with the same date, time, and time zone. The switch certificate is valid 24 hours before its creation date and 365 days after its creation date. If the certificate should become invalid, create a new certificate using the `create certificate` CLI command. For information about the `create certificate` CLI command, see the *HP StorageWorks SN6000 Fibre Channel Switch Command Line Interface Guide*.

Consider your requirements for connection security: for the command line interface (SSH), management applications (SSL), or both. If an SSL connection security is required, also consider using the Network Time Protocol (NTP) to synchronize workstations and switches.

## Device security

Device security provides for the authorization and authentication of devices that you attach to a switch. You can configure a switch with a group of devices against which the switch authorizes new attachments by devices, other switches, or devices issuing management server commands. Device security is configured through the use of security sets and groups. Use the CLI to configure device security. For more information about device security configuration, see the *HP StorageWorks SN6000 Fibre Channel Switch Command Line Interface Guide*.

A group is a list of device worldwide names that are authorized to attach to a switch. There are three types of groups: one for other switches (ISL), another for devices (port), and a third for devices issuing management server commands (MS).

A security set is a set of up to three groups with no more than one of each group type. The security configuration is made up of all security sets on the switch. The security database has the following limits:

- Maximum number of security sets is 4.
- Maximum number of groups is 16.
- Maximum number of members in a group is 1,000.
- Maximum total number of group members is 1,000.

In addition to authorization, the switch can be configured to require authentication to validate the identity of the connecting switch, device, or host. Authentication can be performed locally using the switch's security database, or remotely using a RADIUS server such as Microsoft RADIUS. With a RADIUS server, the security database for the entire fabric resides on the server. In this way, the security database can be managed centrally, rather than on each switch. You can configure up to five RADIUS servers to provide failover.

You can configure the RADIUS server to authenticate just the switch or both the switch and the initiator device if the device supports authentication. When using a RADIUS server, every switch in the fabric must have a network connection. A RADIUS server can also be configured to authenticate user accounts as described in "[User account security](#)" on page 30. A secure connection is required to authenticate user logins with a RADIUS server. For more information, see "[Connection security](#)" on page 30.

Consider the devices, switches, and management agents and evaluate the need for authorization and authentication. Also consider whether the security database is to be distributed on the switches or centralized on a RADIUS server and how many servers to configure. Use the CLI to configure RADIUS servers. For more information about RADIUS server configuration, see the *HP StorageWorks SN6000 Fibre Channel Switch Command Line Interface Guide*.

## Fabric management

The Simple SAN Connection Manager application is a GUI-based management application for HP StorageWorks that runs on the management station. It provides basic automated configuration and management of switches, HBAs, and storage devices. Switch management functions include IP address configuration and limited control of zoning. Simple SAN Connection Manager version 3.0 or later is required for the HP SN6000 Fibre Channel Switch.

The browser-based application, QuickTools, and the CLI reside in the switch firmware and provide for the management of individual switches in a single fabric.

Consider how many fabrics and switches will be managed, how many workstations are needed, and whether the fabrics will be managed with Simple SAN Connection Manager, QuickTools, or the CLI.

A switch supports a combined maximum of 19 logins, which are reserved as follows:

- 4 logins or sessions for internal applications, such as management server and SNMP
- 9 high priority Telnet sessions
- 6 logins or sessions for Simple SAN Connection Manager inband and out-of-band logins, QuickTools logins, and Telnet logins.

Additional logins will be refused.



# 3 Installation

This section describes how to install and configure the switch. The following topics are covered:

- [Site requirements](#), page 33
- [Installing a switch](#), page 34
- [Installing firmware](#), page 43
- [Adding a switch to an existing fabric](#), page 45
- [Installing feature license keys](#), page 46
- [Configuring Call Home to HP Services \(optional\)](#), page 46

## Site requirements

Consider the following items when installing an SN6000 Fibre Channel Switch:

- [Management Station and Workstation requirements](#), page 33
- [Switch power requirements](#), page 34
- [Environmental conditions](#), page 34

## Management Station and Workstation requirements

The management station requirements for Simple SAN Connection Manager are described in [Table 6](#). Workstation requirements for QuickTools are described in [Table 7](#).

**Table 6** Management station requirements for Simple SAN Connection Manager

Operating System	<ul style="list-style-type: none"><li>• Windows Server 2003 R2 x64/x86 with SP2 This requires Microsoft hotfix QFE932755 (updated Storport storage driver). The update is available on the Microsoft website: <a href="http://support.microsoft.com/kb/932755">http://support.microsoft.com/kb/932755</a>.</li><li>• Windows Storage Server 2003 R2 x64/x86 with SP2. This requires Microsoft hotfix QFE932755 (updated Storport storage driver). The update is available on the Microsoft website: <a href="http://support.microsoft.com/kb/932755">http://support.microsoft.com/kb/932755</a>.</li><li>• Windows Server 2008 x64/x86 with SP1.</li></ul>
Memory	512 MB
Disk Space	200 MB per installation
Processor	2 GHz or faster
Internet browser	Microsoft Internet Explorer 5.0 or later Netscape Navigator 6.0 and later Mozilla 1.5 and later Firefox 1.0 and later Java Runtime Environment 1.5 or higher
Hardware	CD ROM drive RJ-45 Ethernet port PCI-e slots for the HP StorageWorks PCI-e FC HBA

**Table 7** Workstation requirements for QuickTools

Operating systems	Windows 2003 and XP SP1/SP2 Red Hat Enterprise Linux 4, 5 SUSE Linux Enterprise Server 9 and 10
Memory	512 MB
Processor	2 GHz or faster
Internet Browser	Microsoft Internet Explorer 6.0 or later Netscape Navigator 6.0 and later Mozilla 1.5 and later Firefox 1.5 and later Java Runtime Environment 1.4.2 or later <sup>1</sup>
Hardware	RJ-45 Ethernet port

1. You must disable caching of temporary files and applets in Java to prevent conflicts with past or future versions of QuickTools. Furthermore, you may need to disable caching again after upgrading Java.

Telnet workstations require an RJ-45 Ethernet port or an RS-232 serial port and an operating system with a Telnet client.

## Switch power requirements

Power requirements are 1 Amp at 100 VAC or 0.5 A at 240 VAC.

## Environmental conditions

Consider the factors that affect the climate in your facility such as equipment heat dissipation and ventilation. The switch requires the following operating conditions:

- Operating temperature range: 5°–40°C (41°–104°F)
- Relative humidity: 10–90%, non-condensing

## Installing a switch

Unpack the switch and accessories. The SN6000 Fibre Channel Switch product is shipped with the following components

- One *Read-Me-First* document
- One *End User License Agreement (EULA)*
- *HP StorageWorks 8/20q and SN6000 Fibre Channel Switch Rack-Mount Kit Quick Start Installation Instructions*
- *HP StorageWorks SN6000 Fibre Channel Switch Quick Start Installation Instructions*
- One HP StorageWorks SN6000 Fibre Channel Switch
- One HP StorageWorks 8/20q and SN6000 Fibre Channel Switch Rack-Mount Kit
- One or two standard power cords (depending on the switch model)
- One or two HP Power Distribution Unit (PDU) power cables (depending on the switch model)
- One serial cable
- Four adhesive rubber feet

For the latest product information, including firmware, documentation, and supported SAN configurations, see the following HP website: <http://www.hp.com/go/SN6000>.

Installing a SN6000 Fibre Channel Switch involves the following steps:

1. [Mount the switch](#), page 35
2. [Install the transceivers](#), page 39
3. [Configure the workstation](#), page 39
4. [Apply power to the switch](#), page 40
5. [Connect the management station or workstation to the switch](#), page 41
6. [Configure the switch](#), page 41
7. [Cable devices to the switch](#), page 42

## Mount the switch

The switch can be placed on a flat surface and stacked, or mounted in a 19" Electronics Industries Association (EIA) rack. See "[Weight and physical dimensions](#)" on page 74 for weight and dimensional specifications. Adhesive rubber feet are provided for surface mounts only. Without the rubber feet, the switch occupies 1U of space in an EIA rack.

The rack mount kit is supported with the following HP custom racks only:

- HP 9000 Series Rack
- HP 10000 Series Rack
- HP 10000 G2 Series Rack

## Before you begin

**⚠ WARNING!** To reduce the risk of personal injury or damage to the equipment, ensure that:

- In single-rack installations, stabilizing feet are attached to the rack.
- In multiple-rack installations, racks are coupled together.
- Leveling jacks on the rack are extended to the floor.
- The full weight of the rack rests on the leveling jacks.
- Heavy items, such as uninterruptible power supplies and hard drive storage enclosures, are installed near the bottom of the rack.
- Similar components are installed next to each other in the rack. Because devices are of differing depths, this will facilitate maintenance and service tasks.
- Only one device in a rack is extended at a time. A rack may become unstable if more than one device is extended.

**⚠ CAUTION:**

- For proper airflow, the SFP+ media side (port side) of the device must face the front of the rack. Mounting the switch in this direction allows air to enter from the front of the rack (SFP-port side of switch) and exhaust through the back of the rack (power-supply side of switch). This prevents overheating, which may cause equipment in the rack to fail.
- Allow a minimum of 63.5 cm (25 in.) clearance in front of the rack to allow the doors to open fully, and 76.2 cm (30 in.) in back of the rack to allow for servicing and airflow.
- If the device is mounted in a closed rack or there are multiple rack-mounted devices, make sure that the operating temperature inside the rack enclosure does not exceed the maximum rated ambient temperature.
- Multiple rack-mounted devices connected to the same AC supply circuit may overload that circuit or the AC supply wiring. Consider the power source capacity and the total power usage of all switches on the circuit.
- Reliable grounding in the rack must be maintained.

## Collect the required items

 **NOTE:** The rack mount kit installation requires one technician.

Locate the following items and set them aside:

- SN6000 Fibre Channel Switch
- 8/20q and SN6000 Fibre Channel Switch rack-mount kit
- Smaller items, such as screws, ship in plastic bags in the kit. See [Table 8](#).

Required tools:

- #2 Phillips screwdriver
- 7/16-inch wrench

## Verify the kit contents

Check the contents of the SN6000 Fibre Channel Switch rack mount kit shipping carton to verify that all required parts and hardware are available ([Table 8](#)).

**Table 8** SN6000 Fibre Channel Switch rack mount kit hardware

Item	Description
	Two (2) rear mounting brackets
	Two (2) switch rails
	One (1) filler panel (optional), see <a href="#">step 7</a> .
	Ten (10) M6 machine screws
	Ten (10) M6 cage-nuts for square rack holes
	Ten (10) M6 cage-nuts for round rack holes
	Four (4) 10-32 x .375-inch screws with captive washers
	Two (2) 1/4-20 hex nuts with lock washers
	Two (2) 1/4-inch flat washers

## Rack the switch

1. Remove and discard the four 10-32 screws from the sides of the switch.
2. Attach each rail to the switch using two 10-32 x .375-inch screws with captive washers (Figure 13). Make sure the slotted ends of the rails are on the power-supply side (not the SFP-port side) of the switch.

### Figure 13 Attaching the rails to the switch

3. On the rack vertical posts, mark the holes that will be used by the rail flanges (three on each rear vertical post, two on each front vertical post). Then, from the inside of each vertical post, insert an M6 cage-nut for the rack you are using (square or round hole) into each marked hole (Figure 14). Fasten each rear mounting bracket to the marked holes, using two M6 machine screws.

### Figure 14 Installing the rear mounting brackets

4. Place the switch and rail assembly into the rack through the front, guiding the slotted-rail ends onto the threaded studs of the rear mounting brackets (Figure 15). Fit the posts on the front rail flanges in the holes between the two cage-nuts on each of the front vertical rack posts.

### Figure 15 Installing the switch and rail assembly

5. Fasten each rail flange to the front of the rack using two M6 machine screws (Figure 16).

**Figure 16** Fastening the rail to the front of the rack

6. Fasten each slotted-rail end to the rear mounting bracket using a flat washer and a 1/4-20 hex nut (Figure 17).

**Figure 17** Fastening the rail to the rear mounting bracket

7. Optional: Fasten the filler panel to the rear mounting brackets with two M6 machine screws (Figure 18).

**Figure 18** Installing the filler panel

## Install the transceivers

A small form-factor pluggable (SFP) transceiver is required for each switch port connected to a device or another switch. SFPs are not included with the switch. An XPAK transceiver is required for each switch 10 Gb/s port connected to the 10 Gb/s port of another switch. Only HP transceivers are supported for use in the switch. To install a transceiver, insert the transceiver into any of the active switch ports and gently press until it snaps in place. To remove a transceiver, gently press the transceiver into the port to release the tension, then pull on the release tab or lever and remove the transceiver.

 **TIP:** The transceiver fits only one way. If the transceiver is not installed under gentle pressure, invert it and try again. A new switch has all ports active.

## Configure the workstation

 **NOTE:** If you plan to use Simple SAN Connection Manager or QuickTools to manage the switch, proceed to “[Apply power to the switch](#)” on page 40.

If you plan to use the CLI to configure and manage the switch, you must configure the workstation. This involves setting the workstation IP address for Ethernet connections, or configuring the workstation serial port.

### Configuring the workstation IP address for Ethernet connections

The default IP address of a new switch is 10.0.0.1. To ensure that your workstation is configured to communicate with the 10.0.0 subnet:

- For a Windows workstation:
  - a. Click **Start**, then choose **Settings > Control Panel > Network and Dial-Up Connections**.
  - b. Choose **Make New Connection**.
  - c. Click the **Connect to a private network through the Internet** radio button, then click **Next**.
  - d. Enter **10.0.0.253** for the IP address.
- For a Linux workstation, open a command window and enter the following command where *interface* is your interface name:

```
ifconfig interface ipaddress 10.0.0.253 netmask 255.255.255.0 up
```

### Configuring the workstation serial port

To configure the workstation serial port:

1. Connect a null modem F/F DB9 cable from a COM port on the workstation to the RS-232 serial port on the switch.
2. Configure the workstation serial port according to your platform:

For a Windows workstation:

  - a. Open the HyperTerminal application. Click **Start**, then select **Programs > Accessories > Communications > HyperTerminal**.
  - b. Enter a name for the switch connection and choose an icon in the Connection Description window. Click **OK**.
  - c. Enter the following COM Port settings in the COM Properties window, and click **OK**.
    - Bits per second: 9,600
    - Data Bits: 8
    - Parity: None
    - Stop Bits: 1
    - Flow Control: None

For a Linux workstation:

- a. Set up minicom to use the serial port. Create or modify the `/etc/minirc.dfl` file with the following content.

```
pr portdev/ttyS0
pu minit
pu mreset
pu mhangup
```

- b. Verify that all users have permission to run minicom. Review the `/etc/minicom.users` file and confirm that the line `ALL` exists or that there are specific user entries.

## Apply power to the switch

**⚠ WARNING!** This product is supplied with a 3-wire power cable and plug for the user's safety. Use this power cable in conjunction with a properly grounded outlet to avoid electrical shock. An electrical outlet that is not correctly wired could place hazardous voltage on metal parts of the switch. It is the responsibility of the customer to ensure that the outlet is correctly wired and grounded to prevent electrical shock.

You may require a different power cable in some countries because the plug on the cable supplied with the equipment will not fit your electrical outlet. In this case, you must supply your own power cable. The cable you use must meet the following requirements:

- For 125 Volt electrical service, the cable must be rated at 10 Amps and be approved by Underwriters Laboratories (UL) and Canadian Standards Association (CSA).
- For 250 Volt electrical service: The cable must be rated at 10 Amps, meet the requirements of H05VV-F, and be approved by Verband der Elektrotechnik (VDE), SEMKO, and DEMKO.

To power up a SN6000 Fibre Channel Switch, attach the AC power cord to the receptacle on the back of the switch and to the power source.

The switch runs its self-tests and begins normal operation—this may take a few minutes:

1. The switch LEDs (Input Power, Heartbeat, System Fault) illuminate followed by all port Logged-in LEDs. The Logged-in LEDs that illuminate indicate the ports that are enabled.
2. After a couple of seconds, the System Fault LED is extinguished while the Input Power LED and Heartbeat LED remain illuminated.
3. After approximately one minute, the POST executes and the Heartbeat LED is extinguished.
4. After about another minute, the POST is complete, all LEDs are extinguished, except the Input Power LED and the Heartbeat LED:
  - The Input Power LED remains illuminated indicating that the switch logic circuitry is receiving DC voltage. If not, contact your authorized maintenance provider.
  - The Heartbeat LED indicates the results of the POST. The POST tests the condition of firmware, memories, data-paths, and switch logic circuitry. If the Heartbeat LED blinks steadily about once per second, the POST was successful, and you can continue with the installation process. Any other blink pattern indicates that an error has occurred. For more information, see "[Heartbeat LED blink patterns](#)" on page 52.



## Connect the management station or workstation to the switch

You can manage the switch using the Simple SAN Connection Manager, QuickTools, or the CLI. Simple SAN Connection Manager requires at least one FC connection and an Ethernet connection to the switch. QuickTools requires an Ethernet connection to the switch. The CLI can use an Ethernet connection or a serial connection.

- If this switch is part of the 8Gb Simple SAN Connectivity Kit installation:
  - a. Connect at least one FC cable from the management station to the switch, or to another switch in the same fabric.
  - b. Use a 10/100 Base-T straight cable to connect the switch Ethernet port to the LAN that connects your management station that will run Simple SAN Connection Manager (see Indirect Ethernet in [Figure 19](#)).
- If this switch is a standalone installation and you plan to use QuickTools or the CLI, connect the switch Ethernet port to the workstation, in one of the following ways:
  - Indirect Ethernet connection from the workstation to the switch RJ-45 Ethernet connector through an Ethernet switch or a hub. This requires a 10/100 Base-T straight cable ([Figure 19](#)).
  - Direct Ethernet connection from the workstation to the switch RJ-45 Ethernet connector. This requires a 10/100 Base-T cross-over cable ([Figure 19](#)).
  - Serial port connection from the workstation to the switch RS-232 serial port connector. This requires a null modem F/F DB9 cable ([Figure 19](#)). This connection supports the CLI only.

1 Indirect Ethernet RJ-45 connection

2 Direct Ethernet RJ-45 connection

3 Serial RS-232 connection

**Figure 19** Management station and workstation cable connections

## Configure the switch

You can configure the switch using Simple SAN Connection Manager, QuickTools, or the CLI.

### Simple SAN Connection Manager switch configuration

For information about installing the Simple SAN Connection Manager application, see the *HP StorageWorks 8Gb Simple SAN Connection Kit Quick Start Instructions*. The Simple SAN Connection Manager software will prompt you to set the switch IP address, administrator password, and default zoning when you first start that application.

When the configuration is complete, proceed to "[Cable devices to the switch](#)" on page 42.

## QuickTools switch configuration

To log in and configure the switch using QuickTools:

1. Open an Internet browser and enter the default IP address 10.0.0.1 to start the QuickTools web applet.
2. Log in to the switch using the default user name (*admin*) and password (*password*).
3. Obtain the IP address and subnet mask from your network administrator.
4. Open the QuickTools Wizards menu and select **Configuration Wizard**. Follow the instructions to set the IP address and the password. Changing the IP address will terminate the QuickTools session.
5. Open an Internet browser again and log in with the new IP address.
6. When the configuration is complete, proceed to ["Cable devices to the switch"](#) on page 42.

## CLI switch configuration

To configure the switch using the command line interface.

1. Open a command window according to the type of workstation and connection.

For an Ethernet connection (all platforms), open a Telnet session with the default switch IP address and log in to the switch with default account name and password (admin/password).

```
telnet 10.0.0.1
Switch Login: admin
Password:      *****
```

 **NOTE:** To insure user account security, change the password for the Admin account name. See the `passwd` command in the *HP StorageWorks SN6000 Fibre Channel Switch Command Line Interface Guide*.

For a Windows serial connection, open the HyperTerminal application on a Windows platform.

- a. Click **Start**, then select **Programs > Accessories > Communications > HyperTerminal**.
- b. Select the connection you created earlier and click **OK**. See ["Configuring the workstation serial port"](#) on page 39.

For a Linux serial connection, open a command window and enter the following command:

```
minicom
```

2. Open an admin session and enter the `set setup system` CLI command. Enter the values you want for switch IP address (EthNetworkAddress) and the network mask (EthNetworkMask). For more information about CLI commands, see the *HP StorageWorks SN6000 Fibre Channel Switch Command Line Interface Guide*.

```
SN6000 FC Switch#> admin start
SN6000 FC Switch (admin) #> set setup system
```

3. Open a Config Edit session and use the `set config switch` CLI command to modify the switch configuration.
4. When the configuration is complete, proceed to ["Cable devices to the switch"](#) on page 42.

## Cable devices to the switch

Connect cables to the SFP transceivers and their corresponding devices, and then energize the devices. Device host bus adapters can have SFP (or SFF) transceivers. Duplex cable connectors are keyed to ensure proper orientation. Choose the Fibre Channel cables with the connector combination that matches the device host bus adapter.

GL\_Ports self configure as FL\_Ports when connected to loop of devices or F\_Ports when connected to a single device. G\_Ports self-configure as F\_Ports when connected to a single device. Both GL\_Ports and G\_Ports self-configure as E\_Ports when connected to another switch.

## Installing firmware

The switch comes with current firmware installed. You can upgrade the firmware from the management station or workstation as new firmware becomes available using Simple SAN Connection Manager, QuickTools, or the CLI. This guide describes the use of QuickTools and the CLI. For information about installing firmware using Simple SAN Connection Manager, see the *HP StorageWorks Simple SAN Connection Manager User Guide*.

- [Using QuickTools to install firmware](#), page 43
- [Using the CLI to install firmware](#), page 44

You can load and activate firmware upgrades on an operating switch without disrupting data traffic or re-initializing attached devices. If you attempt to perform a non-disruptive activation without satisfying the following conditions, the activation will fail. If the non-disruptive activation fails, you will usually be prompted to try again later. Otherwise, the switch will perform a disruptive activation.

- The current firmware version supports the installation and non-disruptive activation of the new firmware. For information about compatible firmware versions, see the firmware release notes.
- No changes are being made to switches in the fabric including powering up, powering down, disconnecting or connecting ISLs, changing switch configurations, or installing firmware.
- No port in the fabric is in the diagnostic state.
- No Zoning Edit sessions are open in the fabric.
- No changes are being made to attached devices including powering up, powering down, disconnecting, connecting, and HBA configuration changes.

If you are installing firmware on more than one switch in the fabric, wait until the activation is complete on the first switch before installing firmware on a second switch. If you attempt to activate firmware on a second switch before activation is complete on the first, you will receive a message advising you to wait and perform a hot reset later on the second switch to complete the installation.

Ports that are stable when the non-disruptive activation begins and then change states, will be reset. When the non-disruptive activation is complete, Simple SAN Connection Manager and QuickTools sessions reconnect automatically. However, Telnet sessions must be restarted manually.

 **TIP:** After upgrading firmware that includes changes to QuickTools, an open QuickTools session may indicate that the firmware is not supported. This means the new firmware is not supported by the previous QuickTools version. To correct this, close the QuickTools session and the browser window, then open a new QuickTools session.

## Using QuickTools to install firmware

To install firmware using QuickTools:

1. In the faceplate display, open the Switch menu and select **Load Firmware**.
2. In the Load Firmware dialog, choose one of the following:
  - Select a firmware image file from the Version drop-down list.
  - Click **Browse** to change the folder (path) to search for firmware image files. Click **Rescan** to search the new folder displayed in the Firmware Image Folder field.
3. Click **Start** to begin the firmware load process. You will be shown a message warning you that the switch will be reset to activate the firmware.
4. Click **OK** to continue firmware installation.
5. Click **Close** to close the Load Firmware dialog.

## Using the CLI to install firmware

The method you choose to install firmware using the CLI depends on the type of firmware activation you want.

- For a disruptive activation, enter the `firmware install` or `image install` command to download the firmware image file from an FTP or TFTP server, unpack it, and activate it in one step. See ["One-step firmware installation"](#) on page 44.
- For a non-disruptive activation, enter the `image fetch` command to download the firmware image file from an FTP or TFTP server. Enter the `image unpack` command to unpack the image file, then enter the `hotreset` command to perform a non-disruptive activation. See ["Custom firmware installation"](#) on page 45.

For information about the CLI commands, see the *HP StorageWorks SN6000 Fibre Channel Switch Command Line Interface Guide*.

### One-step firmware installation

The `firmware install` and `image install` commands download the firmware image file from an FTP or TFTP server to the switch, unpack the image file, and perform a disruptive activation in one step. The installation process prompts you to enter the following:

- The file transfer protocol (FTP or TFTP)
- IP address of the remote host
- An account name and password on the remote host (FTP only)
- Pathname for the firmware image file

For information about the CLI commands, see the *HP StorageWorks SN6000 Fibre Channel Switch Command Line Interface Guide*.

1. Enter the following commands to download the firmware from a remote host to the switch, install the firmware, then reset the switch to activate the firmware.

```
SN6000 FC Switch #> admin start
SN6000 FC Switch #> firmware install

The switch will be reset. This process will cause a
disruption to I/O traffic.

Continuing with this action will terminate all management
sessions, including any Telnet sessions. When the firmware
activation is complete, you may log in to the switch again.

Do you want to continue? [y/n]: y

Press 'q' and the ENTER key to abort this command.
```

2. Enter your choice for the file transfer protocol with which to download the firmware image file. FTP requires an user account and a password; TFTP does not.

```
FTP or TFTP      : ftp
```

3. Enter your account name on the remote host (FTP only) and the IP address of the remote host. When prompted for the source file name, enter the path for the firmware image file.

```
User Account     : johndoe
IP Address       : 10.0.0.254
Source Filename  : 8.0.00.11_epc
About to install image. Do you want to continue? [y/n] y
```

4. When prompted to install the new firmware, enter `y` to continue or `n` to cancel. Entering `y` will disrupt traffic. This is the last opportunity to cancel.

```
About to install image. Do you want to continue? [y/n] y
Connected to 10.20.20.200 (10.20.20.200).
220 localhost.localdomain FTP server (Version wu-2.6.1-18) ready.
```

5. Enter the password for your account name (FTP only).

```
331 Password required for johndoe.  
Password:*****  
230 User johndoe logged in.
```

The firmware will now be downloaded from the remote host to the switch, installed, and activated.

## Custom firmware installation

A custom firmware installation downloads the firmware image file from an FTP or TFTP server to the switch, unpacks the image file, and resets the switch in separate steps. This allows you to choose the type of switch reset and whether the activation will be disruptive (`reset switch` command) or nondisruptive (`hotreset` command). The following example illustrates a custom firmware installation with a nondisruptive activation.

1. Download the firmware image file from the server to the switch.

- If your server has an FTP server, you can enter the `image fetch` command:

```
SN6000 FC Switch (admin) #> image fetch account_name ip_address  
filename
```

- If your server has a TFTP server, you can enter the `image tftp` command to download the firmware image file.

```
SN6000 FC Switch (admin) #> image tftp ip_address filename
```

- If your server has neither an FTP nor a TFTP server, open an FTP session and enter FTP commands:

```
>ftp ip_address or switchname  
user:images  
password: images  
ftp>bin  
ftp>put filename  
ftp>quit
```

2. Display the list of firmware image files on the switch to confirm that the file was loaded.

```
SN6000 FC Switch (admin) $>image list
```

3. Unpack the firmware image file to install the new firmware in flash memory.

```
SN6000 FC Switch (admin) $>image unpack filename
```

4. Wait for the unpack to complete.

```
image unpack command result: Passed
```

5. A message will prompt you to reset the switch to activate the firmware. Use the `hotreset` command to attempt a non-disruptive activation.

```
SN6000 FC Switch (admin) $>hotreset
```

## Adding a switch to an existing fabric

If there are no special conditions to be configured for the new switch, plug in the switch. The switch becomes functional with the default fabric configuration. The default fabric configuration settings are as follows:

- Fabric zoning is sent to the switch from the fabric.
- All ports will be GL\_Ports.
- The default IP address 10.0.0.1 is assigned to the switch without a gateway or boot protocol configured: Reverse Address Resolution Protocol (RARP) Bootstrap Protocol (BOOTP), and Dynamic Host Configuration Protocol (DHCP).

If you are adding a switch to a fabric and do not want to accept the default fabric configuration:

1. If the switch is not new from the factory, reset the switch to the factory configuration before adding the switch to the fabric.
2. If you want to manage the switch through the Ethernet port, you must first configure the IP address.
3. Plug in the inter-switch links (ISL), but do not connect the devices.

4. Configure the port types for the new switch. The ports can be G\_Port, GL\_Port, F\_Port, FL\_Port, TR\_Port, or Donor.
5. Connect the devices to the switch.
6. Make any necessary zoning changes.

## Installing feature license keys

For information about available license keys, see “[Feature licenses](#)” on page 23. To install a license key using QuickTools:

1. Open the Switch Menu and select **Features** to open the Feature Licenses dialog.
2. In the Feature Licenses dialog, click **Add** to open the Add License Key dialog.
3. In the Add License Key dialog, enter the license key in the Key field.
4. Click **Get Description** to display the upgrade description.
5. Click **Add** to upgrade the switch. Allow a minute or two for the upgrade to complete.

To upgrade a switch using the command line interface, see the `feature` command in the *HP StorageWorks SN6000 Fibre Channel Switch Command Line Interface Guide*.

## Configuring Call Home to HP Services (optional)

Call Home to HP Services is supported for the SN6000 Fibre Channel Switch.

- If you have already configured Call Home to HP Services for other HP products using Remote Support Client (RSC), which is part of the Remote Support Pack (RSP), or using Instant Support Enterprise Edition (ISEE), then to configure Call Home to HP Services for the SN6000 Fibre Channel Switch, you must add the switch as a managed system to HP Open Service Event Manager (OSEM) and then configure SNMP traps in the switch.
- If you have not already configured Call Home to HP Services, then you must set up a Central Management Server (CMS) to run HP Systems Insight Manager (SIM), which will direct the installation of RSP applications to support Call Home to HP Services.

## Role of the Remote Support Software Manager

When you install RSP, Remote Support Software Manager (RSSWM) is also installed on your CMS. RSSWM downloads required and recommended software components, including the required software components listed below, which are used to allow communication with HP Services, contract and warranty entitlement capabilities and to provide on-site analysis.

- Remote Support Client (RSC)
- Remote Support Common Components (MC3)
- Remote Support Eligible Systems List
- Open Service Event Manager (OSEM)
- Web-Based Enterprise Services (WEBES)

These and other software management options you select are downloaded by RSSWM. Once configured, RSSWM will download and install updated versions as they become available according to the policies selected during the configuration of RSSWM.

## Role of OSEM and versions required

OSEM collects and formats problem reports from various HP customer systems, including the SN6000 Fibre Channel Switch. OSEM uses the Ethernet (LAN) connection on the switches to receive event notifications through SNMP traps sent from the switches, and then sends automated notification messages to local e-mail recipients (if so configured) and to HP Services through RSC or ISEE. These applications, in turn, send the event message over the internet to HP Services.

OSEM version 1.4.5, SIM 5.1 (which includes RSP version 5.05), and ISEE version A.03.95 are the minimum versions required to support SN6000 Fibre Channel Switch Call Home to HP Services.

## Installation instructions and documentation for SIM, RSP, OSEM, and ISEE

Software, installation instructions, release notes, and other documentation for SIM, RSP, OSEM, and ISEE Standard Configuration are available at no charge from the following HP websites:

- For SIM at <http://www.hp.com/go/hpsim>
- For RSP at <http://www.hp.com/go/ServiceEssentials>
- For OSEM at <http://h18023.www1.hp.com/support/svctools/OSEM/index.html>
- For ISEE at <http://www.hp.com/hps/tech/resources/elect/isee.htm>

### RSP requirements for the CMS

RSP requires that the CMS be a Windows-based system with the following characteristics:

Hardware:

- Any HP ProLiant x86 or HP ProLiant x64 system
- 2.4-GHz processor minimum
- 3 GB RAM minimum; 4 GB RAM if more than 100 devices to be monitored
- 500 MB free disk space minimum

Operating system:

- Microsoft Windows 2000 Server, SP4 for x86
- Microsoft Windows 2000 Advanced Server, SP4 for X86
- Microsoft Windows Server 2003 Standard or Enterprise Edition for x86 with SP1 (running on x86 or x64/AMD64 platforms)
- Microsoft Windows Server 2003 for x64
- Microsoft Windows 2003 SMB, with SP1
- Microsoft Windows 2003 Server with installed Multilingual User Interface Pack (MUI)
- Microsoft Windows 2003 Server with English, French, Italian, German, Spanish and Dutch International Server

Supported Web browsers:

- Internet Explorer, Version 6.0 and 7.0
- Mozilla, Versions 1.5, 1.6, and 1.7
- Firefox, Versions 1.0.2, 1.5, and 2.0

Applications:

- Java Virtual Machine plug-in for Internet Explorer

 **NOTE:** Java plug-in is not installed by default in the Internet Explorer Web Browser for 32-bit and x64 editions of Windows Server 2003.

## Infrastructure requirements for implementing Call Home to HP Services

To implement Call Home to HP Services, the following infrastructure requirements must be met:

- Internet access to the Central Management Server running RSC, or a server running ISEE. (Required because notification messages are sent by RSC or ISEE to HP over the Internet.)
- OSEM can run on the same server as RSC or ISEE or on a server that has LAN access to the server running RSC or ISEE.
- The server running OSEM must have LAN access to the SN6000 Fibre Channel Switches to receive SNMP traps from the switches.
- If a fire wall is installed, the following ports must be open:
  - Port 162, which receives SNMP traps from the switches, because OSEM uses Microsoft SNMP services
  - Port 2069, to communicate with web browsers seeking remote access to OSEM

## Configuring Call Home to HP services

To configure Call Home to HP services:

1. Make sure SIM and RSC, or ISEE are installed on a server that has Internet access. For software, installation instructions, and other documentation for SIM, RSP, and ISEE Standard Configuration, see the HP websites listed in "[Installation instructions and documentation for SIM, RSP, OSEM, and ISEE](#)" on page 47.
2. Make sure OSEM is installed on a server that has Ethernet access to the server running SIM and RSC or ISEE, and to the SN6000 Fibre Channel Switches.

 **NOTE:** OSEM can also be installed on the server that is used to run ISEE or SIM and RSC.

3. To enable a switch to Call Home to HP Services, configure an SNMP trap in the switch using QuickTools or the CLI, as described in the following procedures:

### To configure an SNMP trap using QuickTools:

- a. Enter the IP address of the switch into the web browser of a server that has LAN access to the switch, and login to the switch.
- b. To open the SNMP Properties dialog box: In the fabric tree, click the switch graphic for the switch you are configuring to open its faceplate display, and then select **Switch > SNMP Properties**.
- c. In the SNMP Properties dialog, select the tab for a trap that is not currently in use.
- d. In the display for the selected trap, select the **Trap Enabled** checkbox to enable the trap.
- e. In the Trap Version field, select the trap version **V1**.
- f. In the Trap Severity field, select **Critical**.
- g. In the Trap Address field, enter the IP address of the server running OSEM.
- h. In the Trap Port field, enter the trap port number used by OSEM (the OSEM default trap port is 162).
- i. In the Trap Community field, enter the trap community name. The name can be up to 32 characters and must agree with the community name used in the OSEM application. The following characters may not be used in the user-defined fields: pound sign (#), semi-colon (;), and comma (,).
- j. Click **OK** to enable the changes.

For more information about QuickTools, see the *HP StorageWorks SN6000 Fibre Channel Switch QuickTools Switch Management User Guide*.

### To configure an SNMP trap using the CLI:

- a. Telnet to the IP address of the switch from a server that has LAN access to the switch, and login to the switch.
- b. To modify the SNMP configuration, open an admin session and enter the `set setup snmp trap` CLI command. This will display the current configuration of SNMP trap parameters, followed by queries to allow changes to these parameters. Enter changes as needed to the trap enabled state, IP address, port number, severity, version, and community name.



The following example configures SNMP trap 1:

```
SN6000 FC Switch #> admin start
SN6000 FC Switch (admin) #> set setup snmp trap 1
A list of attributes with formatting and current values will follow.
Enter a new value or simply press the ENTER key to accept the current value.
If you wish to terminate this process before reaching the end of the list
press 'q' or 'Q' and the ENTER key to do so.
```

Current Values:

```
Trap1Enabled      False
Trap1Address      10.0.0.254
Trap1Port         162
Trap1Severity     warning
Trap1Version      2
Trap1Community    public
```

New Value (press ENTER to not specify value, 'q' to quit):

```
Trap1Enabled      (True / False)           :True
Trap1Address      (hostname, IPv4, or IPv6 Address) :10.20.30.40
Trap1Port         (decimal value, 1-65535)       :
Trap1Severity     (select a severity level)
                  1=unknown          6=warning
                  2=emergency        7=notify
                  3=alert            8=info
                  4=critical          9=debug
                  5=error            10=mark           :4
Trap1Version      (1 / 2)                  :1
Trap1Community    (string, max=32 chars)       :OSEMcommunity
```

Do you want to save and activate this snmp setup? (y/n): [n]

For more information about CLI commands, see the *HP StorageWorks SN6000 Fibre Channel Switch Command Line Interface Guide*.

4. Configure the switches in OSEM by adding each SN6000 Fibre Channel Switch as a Managed System configured with System Type set to **FC Switch** and the IP address for the switch. For detailed instructions, see the OSEM documentation available at the websites listed in "[Installation instructions and documentation for SIM, RSP, OSEM, and ISEE](#)" on page 47.



## 4 Diagnostics and troubleshooting

Diagnostic information about the switch is available through the switch LEDs and the port LEDs. Diagnostic information is also available through the CLI, QuickTools, or Simple SAN Connection Manager event logs and error displays. This section describes the following types of diagnostics:

- [Switch diagnostics](#), page 51 describes the Input Power LED and System Fault LED indications.
- [Power-On self test diagnostics](#), page 52 describes the Heartbeat LED and the port Logged-in LED indications.
- [Transceiver diagnostics](#), page 56 lists the transceiver diagnostic information that is available.

This section also describes using maintenance mode to recover a disabled switch. See ["Recovering a switch using maintenance mode"](#) on page 57.

### Switch diagnostics

The SN6000 Fibre Channel Switch has three switch LEDs that are used for diagnostics: Input Power LED, Heartbeat LED, and the System Fault LED ([Figure 20](#)).

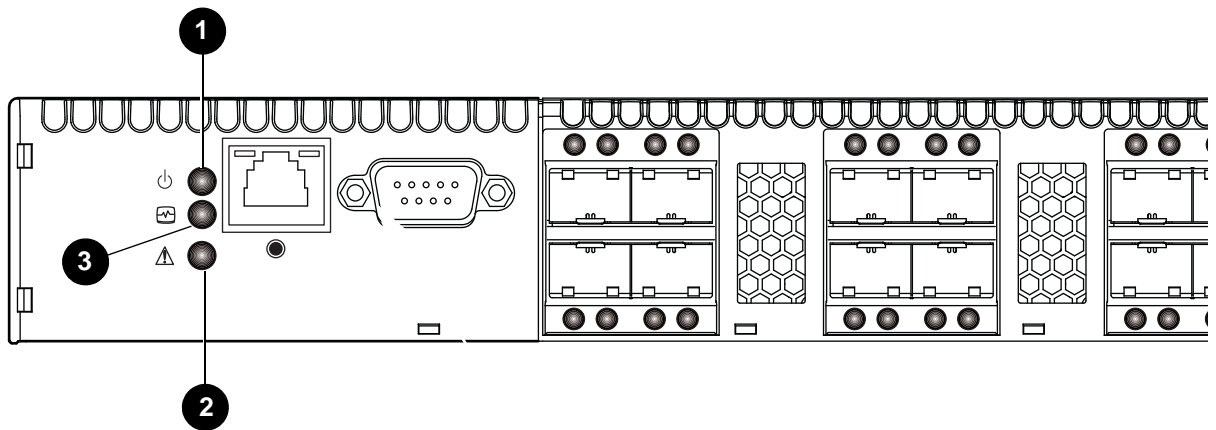

1 Input Power LED

2 System Fault LED

3 Heartbeat LED

**Figure 20** Switch LEDs

The following conditions are described in this section:

- [Input power LED is extinguished](#), page 51
- [System fault LED is illuminated](#), page 52

### Input power LED is extinguished

The Input Power LED illuminates to indicate that the switch logic circuitry is receiving proper voltages. If the Input Power LED is extinguished:

1. Inspect the power cords and connectors. Is the cord unplugged? Is the cord or connector damaged?
  - Yes—Make necessary corrections or repairs. If the condition remains, continue.
  - No—Continue.
2. Inspect the AC power source. Is the power source delivering the proper voltage?
  - Yes—Continue.
  - No—Make necessary repairs. If the condition remains, contact your authorized maintenance provider.

## System fault LED is illuminated

The System Fault LED illuminates to indicate that a fault exists in the switch firmware or hardware. If the System Fault LED illuminates, identify the Heartbeat LED error blink pattern and take the necessary actions. See ["Heartbeat LED blink patterns"](#) on page 52.

## Power-On self test diagnostics

The switch performs a series of tests as part of its power-up procedure. The POST diagnostic program performs the following tests:

- Checksum tests on the boot firmware in Programmable read-only memory (PROM) and the switch firmware in flash memory
- Internal data loopback test on all ports
- Access and integrity test on the Application-specific integrated circuit (ASIC)

During the POST, the switch logs any errors encountered. Some POST errors are critical, others are not. The switch uses the Heartbeat LED and the Logged-in LED to indicate switch and port status. A critical error disables the switch so that it will not operate. A non-critical error allows the switch to operate, but disables the ports that have errors. If two or more ports fail the POST, the entire switch is disabled. Whether the problem is critical or not, contact your authorized maintenance provider.

If there are no errors, the Heartbeat LED blinks at a steady rate of once per second. If a critical error occurs, the Heartbeat LED will show a blink pattern that indicates an error, and the System Fault LED will illuminate. If there are non-critical errors, the switch disables the failed ports and flashes the associated Logged-in LEDs. For more information, see ["Heartbeat LED blink patterns"](#) on page 52.

## Heartbeat LED blink patterns

The Heartbeat LED indicates the operational status of the switch. When the POST completes with no errors, the Heartbeat LED blinks at steady rate of once per second. When the switch is in maintenance mode, the Heartbeat LED illuminates continuously. For more information, see ["Recovering a switch using maintenance mode"](#) on page 57. All other blink patterns indicate critical errors. In addition to producing a Heartbeat error blink patterns, a critical error also illuminates the System Fault LED.

The Heartbeat LED shows an error blink pattern for the following conditions:

- 1 blink—Normal operation
- 2 blinks—[Internal firmware failure blink pattern](#), page 52
- 3 blinks—[Fatal POST error blink pattern](#), page 53
- 4 blinks—[Configuration file system error blink pattern](#), page 53
- 5 blinks—[Over-temperature blink pattern](#), page 53

## Internal firmware failure blink pattern

An internal firmware failure blink pattern is 2 blinks followed by a two second pause. The 2-blink error pattern indicates that the firmware has failed, and that the switch must be reset. Momentarily press and release the Maintenance button to reset the switch.

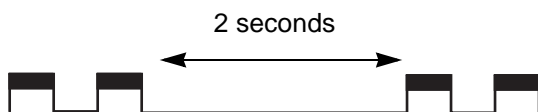

## Fatal POST error blink pattern

A system error blink pattern is 3 blinks followed by a 2-second pause. The 3-blink error pattern indicates that a POST failure or a system error has left the switch inoperable. If a system error occurs, contact your authorized maintenance provider. Momentarily press and release the Maintenance button to reset the switch.

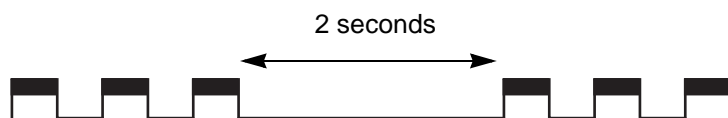

## Configuration file system error blink pattern

A configuration file system error blink pattern is 4 blinks followed by a 2-second pause. The 4-blink error pattern indicates that a configuration file system error has occurred, and that the configuration file must be restored.

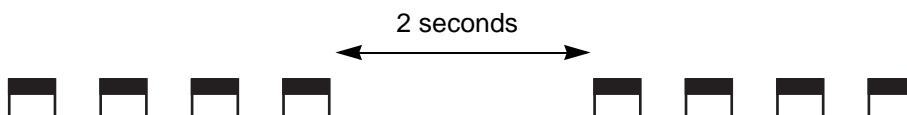

To restore the switch configuration:

1. Establish communications with the switch using Telnet. Enter one of the following on the command line:  

```
telnet xxx.xxx.xxx.xxx
```

or  

```
telnet switchname
```

where *xxx.xxx.xxx.xxx* is the switch IP address and *switchname* is the switch name associated with the IP address.
2. A Telnet window opens prompting you for a login. Enter an account name and password. The default account name and password are `admin` and `password` respectively.
3. Open an admin session to acquire the necessary authority.  

```
SN6000 $> admin start
```
4. Restore the configuration. When the restore is complete, the switch will reset.  

```
SN6000 (admin) $> config restore
```

If a configuration does not exist, enter the `config backup` CLI command, then enter the `config restore` command.

## Over-temperature blink pattern

An over-temperature blink pattern is 5 blinks followed by a 2-second pause. The 5-blink error pattern indicates that the air temperature inside the switch has exceeded the failure temperature threshold.

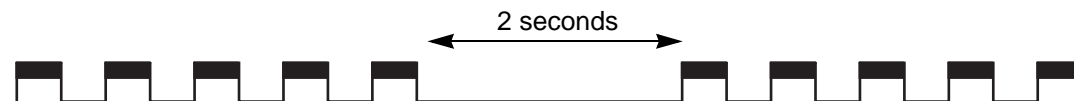

If the Heartbeat LED shows the over-temperature blink pattern:

1. Inspect the switch vents. Are the intake and exhaust vents clear?
  - Yes—Continue.
  - No—Remove any debris from fan intake and exhaust if necessary. If the condition remains, continue.
2. Consider the ambient air temperature near the switch and clearance around the switch. Make necessary corrections. If the condition remains, power down the switch and contact your authorized maintenance provider.

## Logged-in LED indications

Port diagnostics are indicated by the Logged-in LED for each port ([Figure 21](#)).

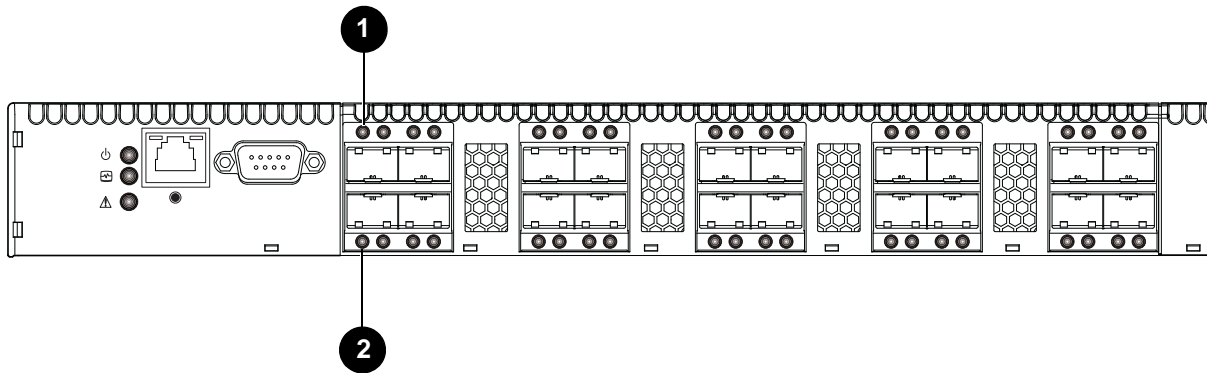

1 Logged-in LED (port 0)

2 Logged-in LED (port 10)

**Figure 21** Logged-in LED

The Logged-in LED has three indications:

- Continuous illumination: A device is logged in to the port.
- Flashing once per second: A device is logging in to the port, or the port is in the diagnostics state.
- Flashing twice per second: The port is down, offline, or an error has occurred.

If a Logged-in LED is flashing two times per second, review the event browser for alarm messages regarding the affected port. You can also inspect the alarm log using the command line interface, `show alarm` command. If there is an error, alarm messages may point to one or more of the following conditions:

- [E\\_Port isolation](#), page 54
- [Excessive port errors](#), page 55

## E\_Port isolation

A Logged-in LED error indication is often the result of E\_Port isolation. E\_Port isolation can be caused by the following:

- Security failure
- A port configured as an F\_Port or an FL\_Port is connected to another switch
- Conflicting domain IDs
- Conflicting timeout values
- Conflicting zone membership between active zone sets
- Connection to a B-series or C-series switch

Using QuickTools, review the event browser, and perform the following procedure to diagnose and correct an isolated E\_Port:

1. Does the QuickTools event browser show an alarm about an invalid attach on the affected port?
  - Yes—If you have configured device security, review the ISL group in the active security set to ensure that the membership includes the necessary ports and that the secrets on all switches are correct.
  - No—Continue.
2. Does the QuickTools event browser show a repeating alarm about an unsupported E\_Port command on the affected port?
  - Yes—The port is configured as an FL\_Port and connected to another switch. Correct the port connection or the port type.
  - No—Continue.

3. Display the fabric domain IDs using the `show domains` CLI command or by selecting the QuickTools **Switch** tab, **Summary** icon. Are all domain IDs in the fabric unique?
  - Yes—Continue.
  - No—Correct the domain IDs on the offending switches using the `set config switch` CLI command or the QuickTools Switch Properties dialog. Reset the port. If the condition remains, continue.
4. Compare the RA\_TOV and ED\_TOV timeout values for all switches in the fabric using the `show config switch` CLI command or by selecting the QuickTools **Switch** tab, **Advanced** icon. Is each timeout value the same on every switch?
  - Yes—Continue.
  - No—Correct the timeout values on the offending switches using the `set config switch` CLI command or selecting **Switch>Advanced Switch Properties** in QuickTools. Reset the port. If the condition remains, continue.
5. Display the active zone set on each switch using the `zoning active` CLI command or by selecting the QuickTools **Active Zoneset** tab. Compare the zone membership between the two active zone sets. Are they the same?
  - Yes—Contact your authorized maintenance provider.
  - No—Deactivate one of the active zone sets or edit the conflicting zones so that their membership is the same, then reset the port. If the condition remains, contact your authorized maintenance provider.

---

 **NOTE:** E\_Port isolation can be caused by merging two fabrics whose active zone sets have two zones with the same name, but different membership.

---

6. Is the port connected to a switch that supports connection to a TR\_Port of an SN6000 Fibre Channel Switch?
  - Yes—Configure the port as a TR\_Port and map the local and remote fabric devices.
  - No—Contact your authorized maintenance provider.

### Excessive port errors

The switch can monitor a set of port errors and generate alarms based on user-defined sample windows and thresholds. These port errors include the following:

- Cyclic Redundancy Check (CRC) errors
- Decode errors
- ISL connection count
- Device login errors
- Device logout errors
- Loss-of-signal errors

Port threshold alarm monitoring is disabled by default. For information about managing port threshold alarms, see the *HP StorageWorks SN6000 Fibre Channel Switch Command Line Interface Guide*.

If the count for any of these errors exceeds the rising trigger for three consecutive sample windows, the switch generates an alarm and disables the affected port, changing its operational state to “down.” Port errors can be caused by the following:

- Triggers are too low or the sample window is too small
- Faulty Fibre Channel port cable
- Faulty SFP
- Faulty port
- Faulty device or HBA

Review the event browser to determine if excessive port errors are responsible for disabling the port. Look for a message that mentions one of the monitored error types indicating that the port has been disabled, then perform the following procedure:

1. Examine the alarm configuration for the associated error using the `show config threshold` CLI command. See the `show config threshold` CLI command in the *HP StorageWorks SN6000 Fibre Channel Switch Command Line Interface Guide*. Are the thresholds and sample window correct?
  - Yes—Continue
  - No—Correct the alarm configuration. If the condition remains, continue.
2. Reset the port, then perform an external port loopback test to validate the port and the SFP. For information about testing ports, see the *HP StorageWorks SN6000 Fibre Channel Switch Command Line Interface Guide* or the *HP StorageWorks SN6000 Fibre Channel Switch QuickTools Switch Management User Guide*. Does the port pass the test?
  - Yes—Continue
  - No—Replace the SFP and repeat the test. If the port does not pass the test, contact your authorized maintenance provider. Otherwise continue.
3. Replace the Fibre Channel port cable. Is the problem corrected?
  - Yes—The procedure is complete.
  - No—Continue.
4. Inspect the device to which the affected port is connected and confirm that the device and its HBA are working properly. Make repairs and corrections as needed. If the condition remains, contact your authorized maintenance provider.

## Transceiver diagnostics

You can display the following transceiver information using the `show media` CLI command:

- Port number
- Manufacturer
- Temperature (°C)
- Operating voltage (volts)
- Transmitter bias (milliamperes)
- Transmitter power (milliwatts)
- Receiver power (milliwatts)

The display indicates warning and alarm conditions for both high and low values.

## Power Supply Diagnostics

An SN6000 Fibre Channel Switch power supply has a Status LED (Green) and a Fault LED (Amber) as shown in [Figure 22](#). Under normal operating conditions, the Power Supply Status LED is illuminated and the Power Supply Fault LED is extinguished.

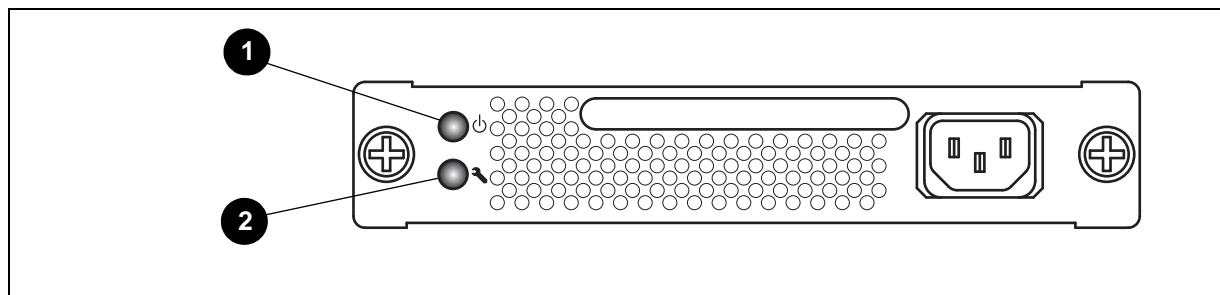

1 Power supply status LED

2 Power supply fault LED

**Figure 22** SN6000 Fibre Channel Switch Power Supply LEDs

Consider the following indications:



- All power supply LEDs are normal, yet the System Fault LED is illuminated and the Heartbeat LED does not show a blink pattern. This means that the two power supplies have different air flow directions. Replace the power supply with the incorrect air flow direction with a power supply that has the correct air flow direction. Air flow direction is marked on the power supply part number label. See ["Power Supply Removal and Replacement"](#) on page 61.
- Power Supply Fault LED is illuminated. This means that the power supply is failing or has failed. Replace the power supply with a power supply that has the same air flow direction. Air flow direction is indicated on the power supply part number label. See ["Power Supply Removal and Replacement"](#) on page 61.

## Recovering a switch using maintenance mode

A switch can become inoperable or unmanageable for the following reasons:

- Firmware becomes corrupt
- IP address is lost
- Switch configuration becomes corrupt
- Password is forgotten

In these specific cases, you can recover the switch using maintenance mode. Maintenance mode temporarily returns the switch IP address to 10.0.0.1 and provides opportunities to do the following:

- [Exiting the maintenance menu \(option 0\)](#), page 58
- [Unpacking a firmware image file in maintenance mode \(option 1\)](#), page 58
- [Resetting the network configuration in maintenance mode \(option 2\)](#), page 58
- [Resetting user accounts in maintenance mode \(option 3\)](#), page 58
- [Copying log files in maintenance mode \(option 4\)](#), page 58
- [Removing the switch configuration in maintenance mode \(option 5\)](#), page 58
- [Remaking the file system in maintenance mode \(option 6\)](#), page 58
- [Resetting the switch in maintenance mode \(option 7\)](#), page 59
- [Updating the boot loader in maintenance mode \(option 8\)](#), page 59

To recover a switch:

1. Place the switch in maintenance mode by pressing and holding the Maintenance button with a pointed tool until only the Heartbeat LED is illuminated, and then release the button. The Heartbeat LED illuminates continuously when the switch is in maintenance mode.
2. Establish a Telnet session with the switch using the maintenance mode IP address 10.0.0.1.
3. Enter the maintenance mode account name (`prom`) and password (`prom`), and press **Enter**.

```
Switch login: prom
Password:xxxx
```

4. The maintenance menu displays several recovery options. To select a switch recovery option, press the corresponding number (displayed in option: field) on the keyboard and press **Enter**.

```
0) Exit
1) Image Unpack
2) Reset Network Config
3) Reset User Accounts to Default
4) Copy Log Files
5) Remove Switch Config
6) Remake Filesystem
7) Reset Switch
8) Update Boot Loader
Option:
```

These options and their use are described in the following subsections.

## Exiting the maintenance menu (option 0)

The **Exit** option closes the current Maintenance menu session. To log in again, enter the maintenance mode account name (`prom`) and password (`prom`). To return to normal operation, momentarily press and release the Maintenance button or power cycle the switch.

## Unpacking a firmware image file in maintenance mode (option 1)

The **Image Unpack** option unpacks and installs new firmware when the current firmware has become corrupt. Before using this option, you must load the new firmware image file onto the switch. To install new firmware using this option:

1. Place the switch in maintenance mode. See the procedure for maintenance mode in “[Recovering a switch using maintenance mode](#)” on page 57.
2. Use FTP to load a new firmware image file onto the switch. See “[Custom firmware installation](#)” on page 45 for an example of how to load the image file. When the download is complete, close the FTP session.
3. Establish a Telnet session with the switch using the default IP address 10.0.0.1.

```
telnet 10.0.0.1
```

4. Enter the maintenance mode account name (`prom`) and password (`prom`), and press **Enter**.

```
Switch login: prom
Password: xxxx
```

5. Select option 1 from the maintenance menu. When prompted for a file name, enter the firmware image file name:

```
Image filename: filename
Unpacking 'filename', please wait...
Unpackage successful.
```

6. Select option **7, Reset Switch**, to reset the switch and exit maintenance mode.

## Resetting the network configuration in maintenance mode (option 2)

The **Reset Network Config** option resets the network properties to the factory default values and saves them on the switch. For default network configuration values, see “[Factory configuration defaults](#)” on page 75.

## Resetting user accounts in maintenance mode (option 3)

The **Reset User Accounts to Default** option restores the password for the Admin account name to the default (password) and removes all other user accounts from the switch.

## Copying log files in maintenance mode (option 4)

The **Copy Log Files** option copies all log file buffers to a file on the switch named `logfile`. You can use FTP to download this file to the workstation, however, you must download `logfile` before resetting the switch. For information about downloading files from the switch, see the *HP StorageWorks SN6000 Fibre Channel Switch Command Line Interface Guide*.

## Removing the switch configuration in maintenance mode (option 5)

The **Remove Switch Config** option deletes all configurations from the switch except the default configuration. This restores switch configuration parameters to the factory defaults. See “[Factory configuration defaults](#)” on page 75 for the factory default values.

## Remaking the file system in maintenance mode (option 6)

The **Remake Filesystem** option resets the switch to the factory default values, including user accounts and zoning. Use this option to recreate the file system when the switch configuration becomes corrupt because of a loss of power. See “[Factory configuration defaults](#)” on page 75 for the factory default values.

---

 **NOTE:** If you choose the **Remake Filesystem** option, you will lose all changes made to the fabric configuration that involve that switch, such as password and zoning changes. You must then restore the switch from an archived configuration or reconfigure the portions of the fabric that involve the switch.

---

## Resetting the switch in maintenance mode (option 7)

The **Reset Switch** option closes the Telnet session, exits maintenance mode, and reboots the switch using the current switch configuration. All unpacked firmware image files that reside on the switch are deleted.

## Updating the boot loader in maintenance mode (option 8)

The **Update Boot Loader** option updates the system boot loader which loads the Linux kernel into memory. Use this option only at the direction of your authorized maintenance provider.



---

## 5 Removal/Replacement

This section describes the removal and replacement procedures for the following field replaceable units (FRU):

- SFP and XPAK transceivers
- Power supplies for the SN6000 Single Supply Switch and the SN6000 Dual Supply Switch models
- The switch is equipped with a battery that powers the non-volatile memory. This memory stores the switch configuration. The battery is not a field replaceable unit.

---

**⚠ WARNING!** The battery may explode if replaced incorrectly. Replace only with the same or equivalent type recommended by the manufacturer. Dispose of the used battery according to the manufacturer's instructions.

---

**⚠ WARNING!** Bei unsachgemäß ausgetauschter Batterie besteht Explosionsgefahr. Die Batterie nur mit der gleichen Batterie oder mit einem äquivalenten, vom Hersteller empfohlenen Batterietyp ersetzen. Die gebrauchte Batterie gemäß den Herstelleranweisungen entsorgen.

---

**⚠ WARNING!** Danger d'explosion si le remplacement de la pile est incorrect. Ne remplacer que par une pile de type identique ou équivalent recommandé par le fabricant. Jeter la pile usagée en observant les instructions du fabricant.

---

**⚠ WARNING!** Peligro de la explosión si la batería es reemplazada incorrectamente. Substituya solamente con el mismo tipo o equivalente recomendado por el fabricante. Deshágase de la batería usada según las instrucciones del fabricante.

---

### Transceiver Removal and Replacement

The SFP and XPAK transceivers can be removed and replaced while the switch is operating without damaging the switch or the transceiver. However, data transmission on the affected port is interrupted until the transceiver is installed.

To remove a transceiver, gently press the transceiver into the port to release the tension, then pull on the release tab or lever and remove the transceiver. Different transceiver manufacturers have different release mechanisms. Consult the documentation for your transceiver. To install the transceiver, insert it into the port and gently press until it snaps in place.

---

**NOTE:** The SFP and XPAK transceivers fits only one way. If the transceiver does not install under gentle pressure, invert it and try again.

---

### Power Supply Removal and Replacement

The SN6000 Dual Power Supply Fibre Channel Switch power supplies are hot-pluggable. This means you can remove or install one of the power supplies while the switch is operating without disrupting service. The power supplies are also interchangeable; that is, the left and right power supplies are the same unit.

---

**NOTE:** Both power supplies must have the same air flow direction to prevent the switch from overheating. To avoid overheating, do not operate the switch with one power supply any longer than necessary.

---

When removing or replacing a power supply, consider the following:

- The left and right power supplies are interchangeable. However, you must orient the power supply so that AC receptacle is on the right.
- Both power supplies must have the same air flow direction. The part number label on the power supply indicates the air flow direction.
- When removing or replacing a power supply on an operating switch, be sure the Heartbeat LED is showing the normal one blink per second. This indicates that the switch will continue operating normally while the power supply is being removed or replaced.

To remove a power supply:

1. Unplug the power cord from the power supply.
2. Using a cross-head screw driver, loosen the two knurled fasteners (Figure 23).
3. Grasp the power supply handle and pull firmly to disengage the modular connector.
4. Remove the power supply from the bay.

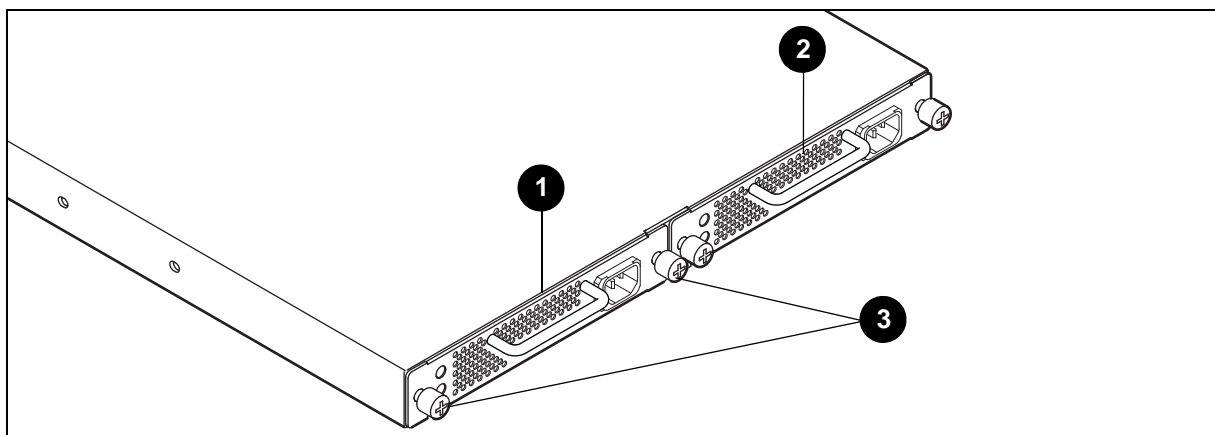

1 Power supply 1

2 Power supply 2

3 Fasteners

### Figure 23 Power Supply Removal

To install a power supply:

1. Confirm that the Heartbeat LED is showing the normal 1 blink per second. This indicates that the switch will continue operating normally while the power supply is being removed or replaced.
2. Confirm that the new power supply is compatible with the switch air flow direction. The part number label on the power supply indicates the air flow direction (Figure 24).
3. With the AC receptacle on the right, slide the power supply into the bay until it is firmly seated. Secure the knurled fasteners by hand.

4. Plug the power cord into the AC receptacle. Confirm that air flow direction is correct.

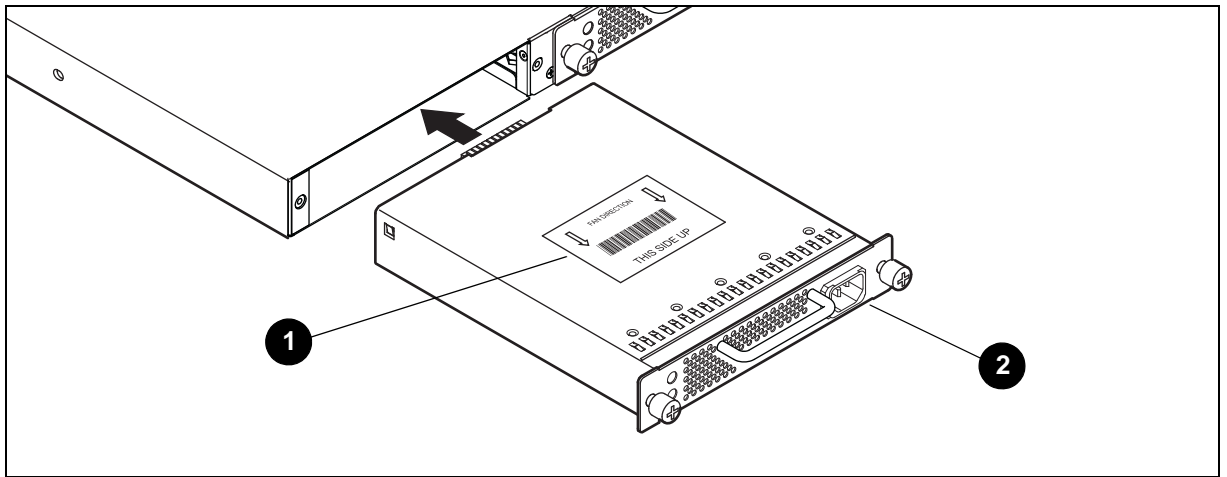

1 Air flow label

2 AC receptacle

#### Figure 24 Power Supply Installation

The power supply in the SN6000 Single Power Supply Fibre Channel Switch can be removed and replaced, but as there is only one power supply, it is not hot-pluggable.

To remove the power supply:

1. Unplug the power cord from the power supply.
2. Using a cross-head screw driver, loosen the two knurled fasteners (in the position of Power Supply 1 in [Figure 23](#)).
3. Grasp the power supply handle and pull firmly to disengage the modular connector.
4. Remove the power supply from the bay.

To install the power supply:

1. Confirm that the new power supply is compatible with the switch air flow direction. The part number label on the power supply indicates the air flow direction ([Figure 24](#)).
2. With the AC receptacle on the right, slide the power supply into the bay until it is firmly seated. Secure the knurled fasteners by hand.





---

# A Regulatory compliance and safety

## Regulatory compliance

### Federal Communications Commission notice for Class A equipment

This equipment has been tested and found to comply with the limits for a Class A digital device, pursuant to Part 15 of the FCC Rules. These limits are designed to provide reasonable protection against harmful interference when the equipment is operated in a commercial environment. This equipment generates, uses, and can radiate radio frequency energy, and, if not installed and used in accordance with the instruction manual, may cause harmful interference to radio communications. Operation of this equipment in a residential area may cause unacceptable interference, in which case the user will be required to correct the interference at their own expense.

### Cables

Connections to this device must be made with shielded cables with metallic RFI/EMI connector hoods in order to maintain compliance with FCC Rules and Regulations.

### Laser device

All HP systems equipped with a laser device comply with safety standards, including International Electrotechnical Commission (IEC) 825. With specific regard to the laser, the equipment complies with laser product performance standards set by government agencies as a Class 1 laser product. The product does not emit hazardous light.

---

#### **WARNING!**

To reduce the risk of exposure to hazardous radiation:

- Do not try to open the laser device enclosure. There are no user-serviceable components inside.
  - Do not operate controls, make adjustments, or perform procedures to the laser device other than those specified herein.
  - Allow only HP authorized service technicians to repair the laser device.
- 

### Laser safety warning

This product uses Class 1 laser optical transceivers to communicate over the fiber optic conductors. The U.S. Department of Health and Human Services (DHHS) does not consider Class 1 lasers to be hazardous. The International Electrotechnical Commission (IEC) 825 Laser Safety Standard requires labeling in English, German, Finnish, and French stating that the product uses Class 1 lasers. Because it is impractical to label the transceivers, the following label is provided in this manual.

## Certification and classification information

This product contains a laser internal to the fiber optic (FO) transceiver for connection to the Fibre Channel communications port.

In the USA, the FO transceiver is certified as a Class 1 laser product conforming to the requirements contained in the Department of Health and Human Services (DHHS) regulation 21 CFR, Subchapter J. A label on the plastic FO transceiver housing indicates the certification.

Outside the USA, the FO transceiver is certified as a Class 1 laser product conforming to the requirements contained in IEC 825-1:1993 and EN 60825-1:1994, including Amendment 11:1996 and Amendment 2:2001.

## Laser product label

The optional Class 1 laser product label (Figure 25) or its equivalent may be located on the surface of the HP-supplied laser device or on the laser device installed in your product.



**Figure 25** Class 1 laser product label

This label indicates that the product is classified as a CLASS 1 LASER PRODUCT.

## International notices and statements

### Canadian notice (avis Canadien)

This equipment does not exceed Class A limits for radio emissions for digital apparatus, set out in Radio Interference Regulation of the Canadian Department of Communications. Operation in a residential area may cause unacceptable interference to radio and TV reception requiring the owner or operator to take whatever steps necessary to correct the interference.



Cet équipement ne dépasse pas les limites de Classe A d'émission de bruits radioélectriques par les appareils numériques, telles que prescrites par le Règlement sur le brouillage radioélectrique établi par le ministère des Communications du Canada. L'exploitation faite en milieu résidentiel peut entraîner le brouillage des réceptions radio et télé, ce qui obligerait le propriétaire ou l'opérateur à prendre les dispositions nécessaires pour en éliminer les causes.

## European Union regulatory notice

This product complies with the following European Union (EU) directives:

- Low Voltage Directive 2006/95/EC
- EMC Directive 2004/108/EC

Compliance with these directives implies conformity to applicable harmonized European standards (European norms), which are listed on the *EU Declaration of Conformity* issued by Hewlett-Packard for this product or product family. This compliance is indicated by the following conformity marking placed on the product:

 <p>This marking is valid for non-telecommunications products and EU harmonized telecommunications products.</p>	 <p>This marking is valid for EU non-harmonized telecommunications products.</p> <p>*Notified body number (used only if applicable—refer to the product label)</p>
---	--

Hewlett-Packard GmbH, HQ-TRE, Herrenberger Strasse 140, 71034 Boeblingen, Germany

## Japanese notice

この装置は、情報処理装置等電波障害自主規制協議会（VCCI）の基準に基づくクラス A 情報技術装置です。この装置を家庭環境で使用すると電波妨害を引き起こすことがあります。この場合には使用者が適切な対策を講ずるよう要求されることがあります。

## Korean notice

### A급 기기 (업무용 정보통신기기)

이 기기는 업무용으로 전자파적합등록을 한 기기이오니 판매자 또는 사용자는 이 점을 주의하시기 바라며, 만약 잘못판매 또는 구입하였을 때에는 가정용으로 교환하시기 바랍니다.

## Taiwan notice

### 警告使用者:

這是甲類的資訊產品，在居住的環境中使用時，可能會造成射頻干擾，在這種情況下，使用者會被要求採取某些適當的對策。



---

## B Electrostatic discharge

This appendix provides the following information:

- [How to prevent electrostatic discharge](#), page 69
- [Grounding methods](#), page 69

### How to prevent electrostatic discharge

To prevent damage to the system, you must follow certain precautions when setting up the system or handling parts. A discharge of static electricity from a finger or other conductor may damage system boards or other static-sensitive devices. This type of damage may reduce the life expectancy of the device.

To prevent electrostatic damage, observe the following precautions:

- Avoid hand contact by transporting and storing products in static-safe containers.
- Keep electrostatic-sensitive parts in their containers until they arrive at static-free workstations.
- Place parts on a grounded surface before removing them from their containers.
- Avoid touching pins, leads, or circuitry.
- Always make sure you are properly grounded when touching a static-sensitive component or assembly.

### Grounding methods

There are several methods for grounding. Use one or more of the following methods when handling or installing electrostatic-sensitive parts:

- Use a wrist strap connected by a ground cord to a grounded workstation or chassis. Wrist straps are flexible straps with a minimum of 1 megohm  $\pm$  10 percent resistance in the ground cords. To provide proper ground, wear the strap snug against the skin.
- Use heel straps, toe straps, or boot straps at standing workstations. Wear the straps on both feet when standing on conductive floors or static-dissipating floor mats.
- Use conductive field service tools.
- Use a portable field service kit with a folding static-dissipating work mat.

If you do not have any of the suggested equipment for proper grounding, have an HP authorized reseller install the part.

---

 **NOTE:** For more information on static electricity, or for assistance with product installation, contact your HP authorized reseller.

---



## C Technical specifications

This appendix contains the specifications for the SN6000 Fibre Channel Switch. See “[General description](#)” on page 11 for the location of all connections, switches, controls, and components.

- [General specifications](#), page 71
- [Maintainability features](#), page 73
- [Fabric management specifications](#), page 73
- [Weight and physical dimensions](#), page 74
- [Electrical specifications](#), page 74
- [Environmental requirements](#), page 74

### General specifications

Table 9 lists general specifications for the SN6000 Fibre Channel Switch.

**Table 9** General specifications

Specification	Description
Fibre Channel protocols	FC-PH Rev. 4.3 FC-PH-2 FC-PH-3 FC-AL Rev 4.6 FC-AL-2 Rev 7.0 FC-FLA FC-GS FC-GS-2 FC-GS-3 FC-FG FC-SW-2 FC-Tape FC-VI Fibre Alliance MIB Version 4.0 Fibre Channel Element MIB RFC 2837\
Fibre Channel classes of service	Classes 2 and 3
Modes of operation	Fibre Channel Classes 2 and 3, connectionless
Port types <ul style="list-style-type: none"><li>• SFP ports</li><li>• XPAK ports</li></ul>	G_Port, GL_Port, F_Port, FL_Port, E_Port, TR_Port G_Port, F_Port, E_Port
Port characteristics	All ports are auto-discovering and self-configuring.
Number of Fibre Channel ports	Available as 24-port base models.

**Table 9** General specifications (Continued)

Specification	Description
Scalability	Maximum 239 switches, depending on configuration. For the latest supported configurations, see the <i>SAN Design Reference Guide</i> available at <a href="http://www.hp.com/go/SANdesignguide">http://www.hp.com/go/SANdesignguide</a> .
Maximum user ports	> 475,000 ports depending on configuration. For the latest supported configurations, see the <i>SAN Design Reference Guide</i> available at <a href="http://www.hp.com/go/SANdesignguide">http://www.hp.com/go/SANdesignguide</a> .
Buffer credits	16 buffer credits per port, ASIC embedded memory
Media type	SFP optical transceiver (ports 0-19) XPAK optical transceiver (ports 20-23)
Fabric port speed	2.125, 4.250, 8.50 Gb/s
Maximum frame size	2,148 bytes (2112 byte payload)
System processor	440EP PowerPc
Fabric latency (intra-switch)	
2 Gb/s to 2 Gb/s	< 0.6 $\mu$ sec
4 Gb/s to 4 Gb/s	< 0.3 $\mu$ sec
8 Gb/s to 8 Gb/s	< 0.2 $\mu$ sec
10 Gb/s to 10 Gb/s	< 0.2 $\mu$ sec
20 Gb/s to 20 Gb/s	< 0.2 $\mu$ sec
Bandwidth	
Point-to-point	425 MB, full duplex at 2 Gb/s 850 MB, full duplex at 4 Gb/s 1,700 MB, full duplex at 8 Gb/s 2,550 MB, full duplex at 10 Gb/s 5,100 MB, full duplex at 20 Gb/s
Aggregate (single switch)	Up to 54 GB full duplex
Air flow	Front-to-back



## Maintainability features

Table 10 lists maintainability features for the SN6000 Fibre Channel Switch.

**Table 10** Maintainability features

Specification	Description
Diagnostics	The POST tests all functional components except SFP transceivers. Port tests include online, internal, and external tests.
User interface	LED indicators
Field replaceable units (FRUs)	Power supply

## Fabric management specifications

Table 11 lists fabric management specifications for the SN6000 Fibre Channel Switch.

**Table 11** Fabric management specifications

Specification	Description
Management methods	Command Line Interface FTP GS-3 Management Server Simple SAN Connection Manager graphical user interface QuickTools web applet SMI-S SNMP TFTP
Maintenance connection	RS-232 connector; null modem F/F DB9 cable
Ethernet connection	RJ-45 connector; 10/100 BASE-T cable
Switch agent	Allows a network management station to obtain configuration values, traffic information, and failure data pertaining to the Fibre Channels using SNMP through the Ethernet interface.

## Weight and physical dimensions

Table 12 lists physical properties for the SN6000 Fibre Channel Switch.

**Table 12** Switch physical dimensions

Property	Value
Height	1U or 43.2 mm (1.70 in)
Width	432 mm (17 in)
Depth	500 mm (19.7 in)
Weight	Dual power supply: 8.16 kg (18 lbs.) Single power supply: 6.8 kg (15 lbs.)

## Electrical specifications

Table 13 lists electrical specifications for the SN6000 Fibre Channel Switch.

**Table 13** Electrical specifications

Specification	Description
Operating voltage	100 to 240 VAC; 50 to 60 Hz
Power source loading (maximum)	1 A at 120 VAC/0.5 A at 240 VAC
Heat output (maximum)	Dual Power: 80 watts nominal; 90 watts typical maximum Single Power: 73 watts nominal; 83 watts typical maximum
Circuit protection	Internally fused

## Environmental requirements

To ensure proper operation, the switch must not be subjected to environmental conditions beyond those for which it was tested. The ranges specified in Table 14 identify the acceptable environment for both operating and non-operating conditions.

**Table 14** Environmental requirements

Condition	Acceptable range during operation	Acceptable range during non-operation
Temperature	5° to 40°C (41° to 104°F)	-20° to 70°C (-4° to 158°F)
Humidity	10% to 90%, non-condensing	10% to 95%, non-condensing
Altitude	3,048 m (0 to 10,000 feet) above sea level	15,240 m (0 to 50,000 feet) above sea level
Vibration (IEC 68-2-6)	5 to 500 Hz, 0.27g, 5 sweeps	2 to 200 Hz, 0.5g, 5 sweeps
Shock (IEC 68-2-7)	3.5g, 3ms, half sine, 20 repetitions	50g, 4216 mmps, 13msec, 3 axis

## D Factory configuration defaults

This appendix describes the following factory configuration defaults:

- [Factory switch configuration](#), page 75
- [Factory port configuration](#), page 76
- [Factory port threshold alarm configuration](#), page 77
- [Factory zoning configuration](#), page 77
- [Factory SNMP configuration](#), page 78
- [Factory switch services configuration](#), page 78
- [Factory DNS host name configuration](#), page 79
- [Factory IP version 4 Ethernet configuration](#), page 79
- [Factory IP version 6 Ethernet configuration](#), page 80
- [Factory event logging configuration](#), page 80
- [Factory NTP server configuration](#), page 80
- [Factory timer configuration](#), page 80
- [Factory RADIUS configuration](#), page 81
- [Factory security configuration](#), page 81
- [Factory Call Home configuration](#), page 82

### Factory switch configuration

Enter the `show config switch` CLI command to display switch configuration values.

**Table 15** Switch configuration defaults

Parameter	Default
AdminState	Online
BroadcastEnabled	True
InbandEnabled	True
FDMIEnabled	True
FDMIEntries	1,000
DefaultDomainID	1 (0x Hex)
DomainIDLock	False
SymbolicName	SN6000 FC Switch
R_A_TOV	10000
E_D_TOV	2000
PrincipalPriority	254
ConfigDescription	Default Config
InteropMode	Standard

## Factory port configuration

Enter the `show config port` CLI command to display port configuration values.

**Table 16** Port configuration defaults

Parameter	Port Defaults
AdminState	Online
LinkSpeed	Ports 0-19: Auto; Ports 20-23: Auto
PortType	Ports 0-19: GL; Ports 20-23: G
SymbolicName	Port <i>n</i> , for ports 0-19 20G- <i>n</i> for ports 20-23, where <i>n</i> is the port number
ALFairness	False
DeviceScanEnabled	True
ForceOfflineRSCN	False
ARB_FF	False
InteropCredit	0
ExtCredit	0
FANEnable	True
AutoPerfTuning	True
LCFEnable	False
MFSEnable	False
MSEnable	True
NoClose	False
IOStreamGuard	Auto
VIEnable	False
PDISCPingEnable	True

## Factory port threshold alarm configuration

Enter `show config threshold` CLI command to display threshold alarm configuration values. If the `ThresholdMonitoringEnabled` parameter is disabled (False), none of the individual threshold monitoring parameter settings can be applied.

**Table 17** Port threshold alarm configuration defaults

Parameter	Default
<code>ThresholdMonitoringEnabled</code>	False
<code>CRCErrorsMonitoringEnabled</code> <ul style="list-style-type: none"><li>• <code>RisingTrigger</code></li><li>• <code>FallingTrigger</code></li><li>• <code>SampleWindow</code></li></ul>	True 25 1 10
<code>DecodeErrorsMonitoringEnabled</code> <ul style="list-style-type: none"><li>• <code>RisingTrigger</code></li><li>• <code>FallingTrigger</code></li><li>• <code>SampleWindow</code></li></ul>	True 25 0 10
<code>ISLMonitoringEnabled</code> <ul style="list-style-type: none"><li>• <code>RisingTrigger</code></li><li>• <code>FallingTrigger</code></li><li>• <code>SampleWindow</code></li></ul>	True 2 0 10
<code>LoginMonitoringEnabled</code> <ul style="list-style-type: none"><li>• <code>RisingTrigger</code></li><li>• <code>FallingTrigger</code></li><li>• <code>SampleWindow</code></li></ul>	True 5 1 10
<code>LogoutMonitoringEnabled</code> <ul style="list-style-type: none"><li>• <code>RisingTrigger</code></li><li>• <code>FallingTrigger</code></li><li>• <code>SampleWindow</code></li></ul>	True 5 1 10
<code>LOSMonitoringEnabled</code> <ul style="list-style-type: none"><li>• <code>RisingTrigger</code></li><li>• <code>FallingTrigger</code></li><li>• <code>SampleWindow</code></li></ul>	True 100 5 10

## Factory zoning configuration

Enter the `show config zoning` CLI command to display zoning configuration values.

**Table 18** Zoning configuration defaults

Parameter	Default
<code>MergeAutoSave</code>	True
<code>DefaultZone</code>	Allow
<code>DiscardInactive</code>	False

## Factory SNMP configuration

Enter the `show setup snmp` CLI command to display SNMP configuration values.

**Table 19** SNMP configuration defaults

Parameter	Default
SNMPEnabled	True
Contact	<syscontact undefined>
Location	<sysLocation undefined>
Description	For AW575A: HP StorageWorks SN6000 Stackable Single Power Supply Fibre Channel Switch  For AW576A: HP StorageWorks SN6000 Stackable Dual Power Supply Fibre Channel Switch
ObjectID	HP StorageWorks SN6000 Stackable Single Power Supply Fibre Channel Switch: 1.3.6.1.4.1.3873.1.24  HP StorageWorks SN6000 Stackable Dual Power Supply Fibre Channel Switch: 1.3.6.1.4.1.3873.1.25
AuthFailureTrap	False
ProxyEnabled	True
SNMPv3Enabled	False
Trap [1-5] Address	Trap 1: 10.0.0.254 Traps 2-5: 0.0.0.0
Trap [1-5] Port	162
Trap [1-5] Severity	Warning
Trap [1-5] Version	2
Trap [1-5] Enabled	False

## Factory switch services configuration

Enter the `show setup services` CLI command to display switch service configuration values.

**Table 20** Services configuration defaults

Parameter	Default
TelnetEnabled	True
SSHEnabled	False
GUIMgmtEnabled	True
SSLMgmtEnabled	False
EmbeddedGUIEnabled	True

**Table 20** Services configuration defaults

Parameter	Default
SNMPEnabled	True
NTPEnabled	False
CIMEnabled	True
FTPEEnabled	True
MgmtServerEnabled	True
CallHomeEnabled	True

## Factory DNS host name configuration

Enter the `show setup system dns` CLI command to display the Domain Name System host name configuration values.

**Table 21** DNS host name configuration defaults

Parameter	Default
DNSClientEnabled	False
DNSLocalHostname	<undefined>
DNSServerDiscovery	Static
DNSServer1Address	<undefined>
DNSServer2Address	<undefined>
DNSServer3Address	<undefined>
DNSSearchListDiscovery	Static
DNSSearchList1	<undefined>
DNSSearchList2	<undefined>
DNSSearchList3	<undefined>
DNSSearchList4	<undefined>
DNSSearchList5	<undefined>

## Factory IP version 4 Ethernet configuration

Enter the `show setup system ipv4` CLI command to display the IP version 4 Ethernet configuration values.

**Table 22** IP version 4 Ethernet configuration defaults

Parameter	Default
EthIPv4NetworkEnable	True
EthIPv4NetworkDiscovery	Static
EthIPv4NetworkIPAddress	10.0.0.1
EthIPv4NetworkIPMask	255.0.0.0
EthIPv4GatewayAddress	10.0.0.254

## Factory IP version 6 Ethernet configuration

Enter the `show setup system ipv6` CLI command to display the IP version 6 Ethernet configuration values.

**Table 23** IP version 6 Ethernet configuration defaults

Parameter	Default
EthIPv6NetworkEnable	True
EthIPv6NetworkDiscovery	Ndp
EthIPv6NetworkAddress	::/64
EthIPv6GatewayAddress	::

## Factory event logging configuration

Enter the `show setup system logging` CLI command to display the event logging configuration values.

**Table 24** Event logging configuration defaults

Parameter	Default
LocalLogEnabled	True
RemotelogEnabled	False
RemoteLogHostAddress	10.0.0.254

## Factory NTP server configuration

Enter the `show setup system ntp` CLI command to display the NTP server configuration values.

**Table 25** NTP server configuration defaults

Parameter	Default
NTPClientEnabled	False
NTPServerAddress	10.0.0.254
NTPServerDiscovery	Static

## Factory timer configuration

Enter the `show setup system timers` CLI command to display the timer configuration values.

**Table 26** Timer configuration defaults

Parameter	Default
AdminTimeout	30
InactivityTimeout	0



## Factory RADIUS configuration

Enter the `show setup radius` CLI command to display RADIUS configuration values.

**Table 27** RADIUS configuration defaults

Parameter	Default
DeviceAuthOrder	Local
UserAuthOrder	Local
TotalServers	0
DeviceAuthServer	False
UserAuthServer	False
AccountingServer	False
ServerIPAddress	10.0.0.1
ServerUDPPort	1812
Timeout	2 seconds
Retries	0
SignPackets	False

## Factory security configuration

Enter the `show config security` CLI command to display security configuration values.

**Table 28** Security configuration defaults

Parameter	Default
AutoSave	True
FabricBindingEnabled	False
PortBindingEnabled	False

## Factory Call Home configuration

Enter the `show setup callhome` CLI command to display call home configuration values.

**Table 29** Call Home service configuration defaults

Parameters	Default
PrimarySMTPServerAddr	0.0.0.0
PrimarySMTPServerPort	25
PrimarySMTPServerEnabled	False
SecondarySMTPServerAddr	0.0.0.0
SecondarySMTPServerPort	25
SecondarySMTPServerEnabled	False
ContactEmailAddress	nobody@localhost.localdomain
PhoneNumber	<undefined>
StreetAddress	<undefined>
FromEmailAddress	nobody@localhost.localdomain
ReplyToEmailAddress	nobody@localhost.localdomain
ThrottleDupsEnabled	True

# Glossary

This glossary defines terms used in this guide or related to this product. It is not a comprehensive glossary of computer terms.

<b>Active firmware</b>	The firmware image on the switch that is in use.
<b>Active zone set</b>	The zone set that defines the current zoning for the fabric. See <a href="#">Zone set</a> .
<b>Activity LED</b>	A port LED that indicates when frames are entering or leaving the port.
<b>Administrative state</b>	Assigned state that determines the operational state of the port or switch. There are two types of administrative states: the administrative state and the configured administrative state. The administrative state is the currently assigned port or switch state, such as <code>Online</code> or <code>Offline</code> . The configured administrative state is the state that is saved in the switch configuration, which determines how the switch or port comes up after a reset or power cycle.
<b>Alarm</b>	A message generated by the switch that requires attention.
<b>Alias</b>	A named set of ports or devices used to make defining zone set membership easier. An alias is not a zone, and it cannot have a zone or another alias as a member. See <a href="#">Zone</a> .
<b>Application-specific integrated circuit (ASIC)</b>	An integrated circuit chip designed for a specific application, such as a transmission protocol or a computer.
<b>Arbitrated loop</b>	A Fibre Channel topology where ports use arbitration to establish a point-to-point circuit.
<b>Arbitrated Loop Physical Address (AL_PA)</b>	A unique one-byte value assigned during loop initialization to each <code>NL_Port</code> on a loop. See <a href="#">NL_Port</a> .
<b>BootP</b>	Boot strap protocol. A type of network server.
<b>Buffer credit</b>	A measure of port buffer capacity, equal to one frame.
<b>Challenge-Handshake Authentication Protocol (CHAP)</b>	An authentication protocol by which a device is challenged to verify its identity before being allowed to log in to a switch.
<b>CIM</b>	Common Interface Model
<b>Class 2 service</b>	A service that multiplexes frames at frame boundaries to or from one or more <code>N_Ports</code> with acknowledgment provided. See <a href="#">N_Port</a> .
<b>Class 3 service</b>	A service that multiplexes frames at frame boundaries to or from one or more <code>N_Ports</code> without acknowledgment. See <a href="#">N_Port</a> .
<b>Common Information Model (CIM)</b>	A switch service that provides for switch management through third-party applications that comply with the Storage Management Initiative–Specification (SMI-S).
<b>Configuration wizard</b>	QuickTools wizard that automates the switch configuration process.
<b>Device security</b>	A component of fabric security that provides for the authorization and authentication of devices that attach to a switch through the use of groups and security sets. See <a href="#">Group</a> and <a href="#">Security set</a> .
<b>Domain ID</b>	User-defined number that identifies the switch in the fabric.
<b>E_Port</b>	Expansion port. A Fibre Channel port that connects to another switch.
<b>Event log</b>	Log of messages describing events that occur in the fabric.
<b>F_Port</b>	Fabric port. A Fibre Channel switch port that supports a connection to a single server or storage device.
<b>Fabric device management interface (FDMI)</b>	An interface by which device host bus adapters (HBAs) can be managed through the fabric.
<b>Fabric management switch</b>	The switch through which the fabric is managed.
<b>Fabric security</b>	A feature that provides security for fabric users and devices, including user account security and fabric services. See <a href="#">Device security</a> and <a href="#">Fabric services</a> .

<b>Fabric services</b>	A component of fabric security that provides for the control of inband management and SNMP on a switch. See <a href="#">Fabric security</a> and <a href="#">Simple Network Management Protocol (SNMP)</a> .
<b>FC port</b>	Fibre Channel port
<b>FL_Port</b>	Fabric loop port. A Fibre Channel switch port that supports a connection to up to 126 server or storage devices.
<b>Flash memory</b>	Memory on the switch that contains the switch control firmware.
<b>Frame</b>	Data unit consisting of start-of-frame (SOF) delimiter, header, data payload, CRC, and end-of-frame (EOF) delimiter.
<b>FRU</b>	Field Replaceable Unit
<b>Group</b>	A list of device worldwide names that are authorized to attach to a switch. There are three group types: one for other switches (ISL), another for devices (port), and a third for devices issuing management server commands (MS).
<b>Heartbeat LED</b>	A switch LED that indicates the status of the internal switch processor and the results of the Power-on self test.
<b>Host bus adapter (HBA)</b>	A circuit board that is installed in a server or storage device through which the device connects to the fabric.
<b>Inband management</b>	The ability to manage a switch through another switch over an inter-switch link.
<b>Initiator</b>	The device that initiates a data exchange with a target device.
<b>In-order-delivery</b>	A feature that requires that frames be received in the same order in which they were sent.
<b>Input power LED</b>	A switch LED that indicates that the switch logic circuitry is receiving proper DC voltages.
<b>Inter-Fabric Zone (IFZ)</b>	A zone that is used to map local devices to devices on a remote HP StorageWorks B-series or C-series fabric across a TR_Port. The zone membership consists of the port WWNs of the local device, the remote device, and the TR_Port. The zone name is a concatenation of the IFZ prefix, the lowest WWN, and the remaining WWN, separated by underscores (_).
<b>Inter-switch link (ISL)</b>	The connection between two switches using E_Ports. See <a href="#">E_Port</a> .
<b>License key</b>	A code associated with a separately-purchased feature that activates that feature on the switch.
<b>Light Emitting Diode (LED)</b>	One of several small lights that indicate the condition of the switch or a Fibre Channel port. See <a href="#">Heartbeat LED</a> , <a href="#">Input power LED</a> , <a href="#">System Fault LED</a> , <a href="#">Activity LED</a> , and <a href="#">Logged-in LED</a> .
<b>Logged-in LED</b>	A Fibre Channel port LED that indicates the logged-in or initialization status of the connected devices.
<b>Maintenance button</b>	Momentary button on the switch used to reset the switch or place the switch in maintenance mode. See <a href="#">Maintenance mode</a> .
<b>Maintenance mode</b>	Maintenance mode sets the IP address to 10.0.0.1 and provides access to the switch for maintenance purposes.
<b>Management Information Base (MIB)</b>	A set of guidelines and definitions for SNMP functions. See <a href="#">Simple Network Management Protocol (SNMP)</a> .
<b>Management station</b>	Workstation or server used to run Simple SAN Connection Manager.
<b>N_Port</b>	Node port. A Fibre Channel device port in a point-to-point or fabric connection.
<b>Network Time Protocol (NTP)</b>	A network protocol that enables a client to synchronize its time with a server.
<b>NL_Port</b>	Node loop port. A Fibre Channel device port that supports arbitrated loop protocol.
<b>N-Port ID Virtualization (NPIV)</b>	A Fibre Channel facility allowing multiple N_Port IDs to share a single physical N_Port.
<b>Pending firmware</b>	The firmware image that will be activated upon the next switch reset.
<b>Port binding</b>	An authorization method that defines a list of device WWNs that can login to a switch port. See <a href="#">Worldwide Name (WWN)</a> .
<b>Power-on self test (POST)</b>	Diagnostics that the switch performs at start up.

<b>Principal switch</b>	The switch in the fabric that manages domain ID assignments. See <a href="#">Domain ID</a> .
<b>QuickTools</b>	A browser-based switch management application that resides in the switch firmware.
<b>Remote Authentication Dial-in Service (RADIUS)</b>	A service that supports the remote authentication of user and device logins to a switch.
<b>Secure shell (SSH)</b>	A protocol that secures connections to the switch for the command line interface.
<b>Secure socket layer (SSL)</b>	A protocol that secures connections to the switch for QuickTools and SMI-S.
<b>Security set</b>	A set of up to three groups containing no more than one of each group type: ISL, Port, or MS. The active security set defines the device security for a switch. See <a href="#">Group</a> .
<b>Simple Network Management Protocol (SNMP)</b>	An application protocol that manages and monitors network communications and functions. It also controls the Management Information Base (MIB). See <a href="#">Management Information Base (MIB)</a> .
<b>Simple SAN Connection Manager (SSCM)</b>	A management application that provides basic automated configuration and management of switches, HBAs, and storage devices.
<b>Small form-factor pluggable (SFP)</b>	A transceiver device, smaller than a GigaBit interface converter, that plugs into the Fibre Channel port.
<b>Stacking cable</b>	An XPAK cable used to connect two or more switches through the 10 Gb/s ports.
<b>Storage Management Initiative–Specification (SMI-S)</b>	A standard that provides for the management of the switch through third-party management applications.
<b>System Fault LED</b>	A switch LED that indicates that a fault exists in the switch firmware or hardware.
<b>Target</b>	A storage device that responds to an initiator device.
<b>TR_Port</b>	Transparent routing port. A port type that uses the Fibre Channel industry standard NPIV to provide access to devices on a remote HP StorageWorks B-series or C-series fabric.
<b>User account</b>	An object stored on a switch that consists of an account name, password, authority level, and expiration date.
<b>User account security</b>	A component of fabric security that provides for the administration and authentication of account names, passwords, expiration dates, and authority level.
<b>Workstation</b>	PC or Linux workstation that manages the switch using QuickTools or the command line interface (CLI).
<b>Worldwide Name (WWN)</b>	A unique 64-bit address assigned to a device by the device manufacturer.
<b>XPAK</b>	A specification authored by a consortium of companies to govern the development of small form factor 10 and 20 Gigabit modules.
<b>Zone</b>	A set of ports or devices grouped together to control the exchange of information.
<b>Zone set</b>	A set of zones grouped together. The active zone set defines the zoning for a fabric. See <a href="#">Zone</a> .
<b>Zoning database</b>	The set of zone sets, zones, and aliases stored on a switch. See <a href="#">Alias</a> , <a href="#">Zone</a> , and <a href="#">Zone set</a> .



# Index

## Numerics

10/100 Base-T straight cable 41

## A

account name  
  default 42  
  FTP 45  
  maintenance mode 57  
active zone set 21  
Activity LED 15, 17  
air flow 72  
alias 21  
altitude 74  
authorization 31

## B

bandwidth 22, 72  
boot loader 59  
browser 33, 34  
buffer credit 22, 72

## C

cable  
  10/100 Base-T 41  
  10/100 Base-T crossover 41  
  null modem F/F DB9 41  
Call Home service  
  configure to HP service 46  
  description 29  
certificate 31  
classes of service 71  
command line interface 19  
Common Information Model 28  
configuration  
  file system error 13, 53  
  remove 58  
  restore default 58  
controls 12  
conventions  
  document 8  
  text symbols 8  
credits 22, 72  
critical error 52

## D

device  
  access 21  
  authentication 31  
  authorization 31  
  cabling 42  
  description 21  
  performance 23  
  security 31

diagnostics 51, 52, 73  
dimensions 74  
disk space 33  
distance 22  
document  
  conventions 8  
documentation, HP website 7  
domain ID  
  conflict 55  
  description 24  
  lock 24

## E

E\_Port 16, 54  
e-mail notification 29  
environmental  
  conditions 34  
  specifications 74  
error  
  critical 52  
  fatal POST 53  
  port 55  
Ethernet  
  direct connection 41  
  indirect connection 41  
  port 17

## F

F\_Port 16  
fabric  
  management 32, 73  
  management switch 17  
  point-to-point bandwidth 72  
  port 15, 16  
  security 30  
factory defaults 58  
Fibre Channel  
  ports 14  
  protocols 71  
Field Replaceable Unit 73  
File Transfer Protocol  
  account name 45  
  description 20  
  service 28  
firmware  
  description 43  
  failure 52  
  install with CLI 44  
  install with QuickTools 43  
  non-disruptive activation 43  
  unpack image 58  
five-switch stacking 25  
FL\_Port 16

flash memory 13  
four-switch stacking 25  
frame size 72  
FRU - See Field Replaceable Unit  
FTP - See File Transfer Protocol

## G

G\_Port 16  
generic ports 15  
GL\_Port 16

## H

hardware requirements 33, 34  
HBA - See Host Bus Adapter  
Heartbeat LED 12, 52  
heat output 74  
help, obtaining 9, 10  
HP  
    services 46  
    storage website 10  
    Subscriber's choice website 9  
    technical support 9  
humidity 34, 74  
HyperTerminal application 39

## I

inband management 28  
Input Power LED 51  
installation 34  
Inter-Fabric Zone 28  
internal firmware failure 52  
internet browser 33, 34

## L

latency 23, 72  
LED  
    Activity 15, 17  
    Heartbeat 12, 52  
    Input Power 12, 51  
    Link Status 17  
    Logged-In 15  
    Logged-in 54  
    System Fault 12, 52  
license key 46  
Link Status LED 17  
log file 58  
Logged-in LED 15, 54  
login limit 32

## M

maintainability 73  
maintenance  
    button 12, 13, 57  
    interface 73  
    menu 57, 58  
    mode 13, 52, 57  
Management Server 28  
management station

    connecting 41  
    requirements 33  
media type 72  
memory  
    flash 13  
    workstation 33, 34  
minicom 40  
multiple switch fabrics 23

## N

non-critical error 52  
non-disruptive activation 43  
N-Port ID Virtualization 26  
NTP - See Network Time Protocol  
null modem F/F DB9 cable 41

## O

Open Service Event Manager 46  
operating systems 33, 34  
over-temperature 53

## P

password  
    file reset 58  
    maintenance mode 57  
    restore default 58  
performance  
    device 23  
    switch 22  
planning 21  
port  
    binding 30  
    buffer credits 22  
    characteristics 71  
    diagnostics 54  
    Ethernet 17  
    fabric 15  
    Fibre Channel 14  
    generic 15  
    LEDs 15  
    maximum number of ports/users 72  
    number of 71  
    security 30  
    serial 17  
    SFP 14  
    speed 72  
    transparent routing 16  
    types 15, 71  
    XPAK 14  
POST - See Power-on self test  
power  
    consumption 74  
    requirements 34  
    source loading 74  
Power Supply Fault LED 18  
Power Supply Status LED 18  
Power-on self test  
    description 52



- fatal error [53](#)
- principal
  - priority [24](#)
  - switch [24](#)
- processor [33](#), [34](#), [72](#)

## Q

- QuickTools
  - service [28](#)
  - web applet [19](#)

## R

- rack mount [35](#)
- rack stability, warning [9](#)
- RADIUS - See Remote Dial-In User Service.
- recovering a switch [57](#)
- remake filesystem [58](#)
- Remote Dial-In User Service [30](#), [31](#)
- Remote Support Pack [47](#)
- Remote Support Software Manager [46](#)
- RS-232 port [17](#)

## S

- scalability [72](#)
- Secure Shell
  - description [30](#)
  - service [28](#)
- Secure Socket Layer service [28](#)
- security
  - certificate [31](#)
  - connection [30](#)
  - database limits [31](#)
  - device [31](#)
  - fabric [30](#)
  - user account [30](#)
- serial port [17](#), [39](#), [41](#)
- SFP - See Small Form-Factor Pluggable
- shock [74](#)
- Simple Mail Transfer Protocol [29](#)
- Simple Network Management Protocol
  - description [20](#)
  - service [28](#)
- site requirements [33](#)
- six-switch stacking [26](#)
- small form-factor pluggable [39](#)
  - port [14](#)
  - transceiver [15](#), [61](#)
- SMI-S - See Storage Management Initiative-Specification
- SMTP - See Simple Mail Transfer Protocol
- SNMP - See Simple Network Management Protocol
- soft zone [21](#)
- SSH - See Secure Shell
- SSL - See Secure Socket Layer
- stacking [24](#)
- Storage Management Initiative-Specification [20](#)
- Subscriber's choice, HP [9](#)
- surface mount [35](#)
- switch

- add to fabric [45](#)
- air flow [72](#)
- configuration [41](#)
- diagnostics [51](#)
- management [19](#)
- management service [28](#)
- power up [40](#)
- recovery [57](#)
- reset [13](#), [59](#)
- services [28](#)
- shock [74](#)
- specifications [71](#)
- vibration [74](#)
- symbols in text [8](#)
- System Fault LED [12](#), [52](#)
- system processor [72](#)

## T

- technical support, HP [9](#)
- Telnet service [28](#)
- temperature
  - error [53](#)
  - operating range [34](#), [74](#)
- text symbols [8](#)
- three-switch-stacking [25](#)
- timeout values [55](#)
- TR\_Port [16](#)
- transceiver [15](#), [39](#), [61](#)
- transceiver diagnostics [56](#)
- transmission rate [22](#)
- transparent routing [26](#)
- transparent routing port [16](#)
- two-switch stacking [24](#)

## U

- user account security [30](#)
- user interface [73](#)

## V

- vibration [74](#)
- voltage [74](#)

## W

- warning
  - rack stability [9](#)
- web applet
  - description [19](#)
  - service [28](#)
- websites
  - HP documentation [7](#)
  - HP storage [10](#)
  - HP Subscriber's choice [9](#)
- workstation
  - configuration [39](#)
  - connecting [41](#)
  - IP address [39](#)
  - operating system [17](#)
  - requirements [33](#)

## X

XPAK port 14

## Z

zone

  conflict 55

  definition 21

zone set

  active 21

  definition 21

zoning

  database 22

  hardware-enforced 21

  limits 22